



Catálogo



OSPANELI



ONDA SERVICIOS PANELES DE IMAGEN S.L.

667 741 357 / 691 655 089

gerencia@ondaservicios.es

www.ospaneli.es



INDICE

EMPRESA.....	5	CAJA MUESTRAS CIERRE IMANTADO ...	21
MATERIALES	8	CAJA MUESTRAS CIERRE IMANTADO ...	22
TABLERO AGLOMERADO	8	CAJA EMBALAJE CIERRE PESTAÑA.....	23
SILICONA / FILM.....	8	CAJA EMBALAJE CIERRE PRECINTO ...	24
PALETS.....	8	CAJON MUESTRAS	25
PANELES.....	9	CAJON PORTAPIEZAS.....	25
PANELES TECNICOS	9	CUNA MADERA	28
PANELES DE MANO	9	MUNERATO DERECHA E IZQUIERDA....	28
ASAS	9	CUNA MADERAS	29
SERVICIOS	10	GRAND WOODS	30
CHAPADO	10	10 PANELES.....	31
RETRACTILADO.....	10	INCLINADA CON TRASERA	32
CAJONES EXPORTACION	10	TOWER.....	33
CAJONES PARA RECICLAJE.....	10	EDILIS Y STYLWOOD	34
DISEÑO DE PROTOTIPOS		MONTAN	35
PERSONALIZADO	13	CUNA METAL	35
BASE SOBREMESA.....	14	MADL	35
BASE SOBREMESA 25 RANURAS.....	14	TOSCANA.....	36
BASE SOBREMESA 7 RANURAS.....	15	CASTOR	37
BASE HIDRAULICO	16	TORRE.....	38
PORTAPIEZAS SOBREMESA		CUNA PANELES DE MANO	39
CON TRASERA.....	17	PORTAPIEZAS.....	40
BASE SUELO.....	18	EXPOSITOR VERTICAL	43
XXL	18	PIE METAL 2P.....	43
CAJA MUESTRAS.....	20	MUEBLE GIRATORIO	44
CAJA MUESTRAS CIERRE CHINO	20	EXTRAIBLE GIRATORIO CON IMANES ...	44
		MUEBLE VERTICAL.....	46

EXTRAIBLE SIMPLE* / DOBLE	46
EXTRAIBLE 10 DOBLE Y 15 DOBLE.....	47
EXTRAIBLE GIRATORIO	48
SILVIA.....	49
SIN TECHO SIMPLE.....	50
SIN TECHO DOBLE.....	51
ELIA.....	52
F22 y F26.....	53
MONACO	54
ARGEL.....	55
SEGRE.....	56
L8 y L10.....	57
TUNICIA SIMPLE.....	58
TUNICIA DOBLE	59
SIN TECHO TECNICO MULTIFORMATO .	60
MUEBLE HORIZONTAL	61
MESA EXTRAIBLE TIPO BANDEJA.....	61
BERLIN SIMPLE	62
BERLIN DOBLE.....	63
MUNICH SIMPLE.....	64
MUNICH DOBLE	65
SHOWROOMS.....	68
MESA TECNICA POLIVALENTE	68
MUEBLE MULTIBANDEJA	69
TECHNIC WALL TILES.....	70
TECHNIC WALL MOSAIC	71
AMBIENTES INTERCAMBIABLES.....	72
MUEBLES MODULARES.....	73
ENFARDADORA PALETS	76

CONTENEDORES	77
MESA DE TRABAJO	77
COMPRESORES	78
BASCULA / RAMPA	79
PINZA PICKING.....	80
PALAS	81
IMAGEN CORPORATIVA	82
FOLDERS / CARPETAS	82
RETRACTILADOS.....	82
ROTULACION VEHICULOS	83
ROPA LABORAL	83
CATALOGOS	84
TARJETAS	84
FLYERS.....	84
MERCHANDISING	84
SUBLIMACION	85
BORDADOS	85
SERIGRAFIA.....	85
VINILO IMPRESION.....	86
VINILO TEXTIL.....	86
CORTE LASER	87
PLANTILLAS	87
ROTULOS / MONOPOSTES.....	88
DISPLAYS.....	89
EXPOSICIONES.....	90
STANDS.....	91



Ospaneli es una empresa dedicada a la industria gráfica que ofrece a sus clientes gran variedad de productos.

Contamos con más de quince años de experiencia. Destacamos por un trato cercano con nuestros clientes y por solucionar sus necesidades con eficacia. Tenemos un gran equipo de profesionales.

Ofrecemos todo lo necesario para una imagen corporativa. Entre nuestros servicios destacamos las impresiones a gran formato, paneles cerámicos, catálogos, ropa laboral personalizada, rotulaciones de vehículos y rotulación en general, tanto para empresas como para particulares, venta de expositores cerámicos a medida y un sinfín de productos de merchandising.

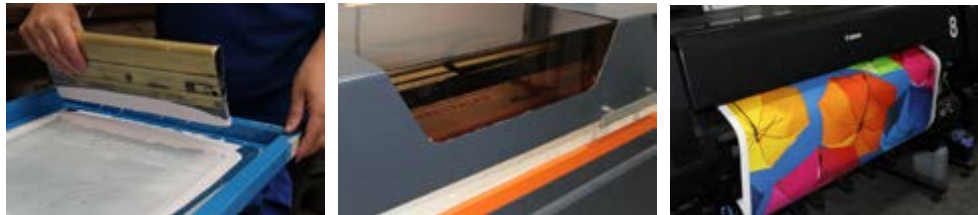



Tel: 964 60 53 30 / 667 741 357 / 691 655 089

gerencia@ondaservicios.es

www.ospaneli.es



The image features a dark grey background with a fine, repeating hexagonal pattern. Overlaid on this are several overlapping circles. A large, central circle is filled with a lighter blue version of the hexagonal pattern and has a thick, solid blue border. To its upper right, a portion of a purple circle with a similar pattern is visible, along with a solid magenta arc. To its lower right, a portion of a yellow-green circle with a similar pattern is visible, along with a solid yellow arc. The text is centered within the blue circle.

PANELES
SERVICIOS
MATERIALES

MATERIALES

TABLERO AGLOMERADO



El precio final dependerá de la cantidad solicitada.
Se sirven paquetes de 50 unidades de 1005x1925x15 mm.

PALETS



Se sirven palets homologados según la normativa CARB-2 para EEUU

SILICONA / FILM



Se sirven palets completos de 60 cajas por palet.
Cada caja dispone de 24 unidades siendo el peso total de 200 Kg/palet.



Se sirven palets completos de 40 bobinas por palet.
Las bobinas son de 50 cm con un peso de 18 Kg.
El peso del palet es de 750Kg.

PANELES

PANELES TECNICOS



PANEL ADHESIVO ESTANDAR (1925x1005x15mm) y MEDIDAS ESPECIALES

OPCIONES:

- Aglomerado 15mm (grosor) / 10mm
- Melamina Blanca / Negra
- Acabado Canteado
- Medidas Especiales
- Paneles Fenolicos



PANEL ADHESIVO PARCIAL HORIZONTAL (700x1005x15mm) + (ALICATADO) + (SUPLEMENTADO)



PANEL ADHESIVO PARCIAL VERTICAL (1925x400x15mm) + (ALICATADO) + (SUPLEMENTADO)

PANELES DE MANO



ASAS



ASAS DE METACRILATO Y DM PERSONALIZABLES

SERVICIOS

CHAPADO



El precio final dependerá del número de piezas a chapar

RETRACTILADO



Ofrecemos servicio de retractilado de piezas

CAJONES EXPORTACION



Fabricamos cajones a medida según las necesidades del cliente

CAJONES PARA RECICLAJE





BASES

MAQUINARIA PARA RETRACTILAR

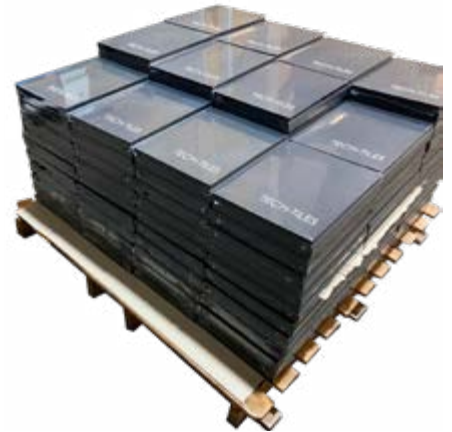

 **OSPANELI**

Tel: 964 60 53 30 / 667 741 357 / 691 655 089

gerencia@ondaservicios.es

www.ospaneli.es

DISEÑO DE PROTOTIPOS PERSONALIZADO



DISEÑAMOS TU PRODUCTO A MEDIDA

CONSULTA PRECIO SIN COMPROMISO

C
E
A
N
E
L

BASE SOBREMESA

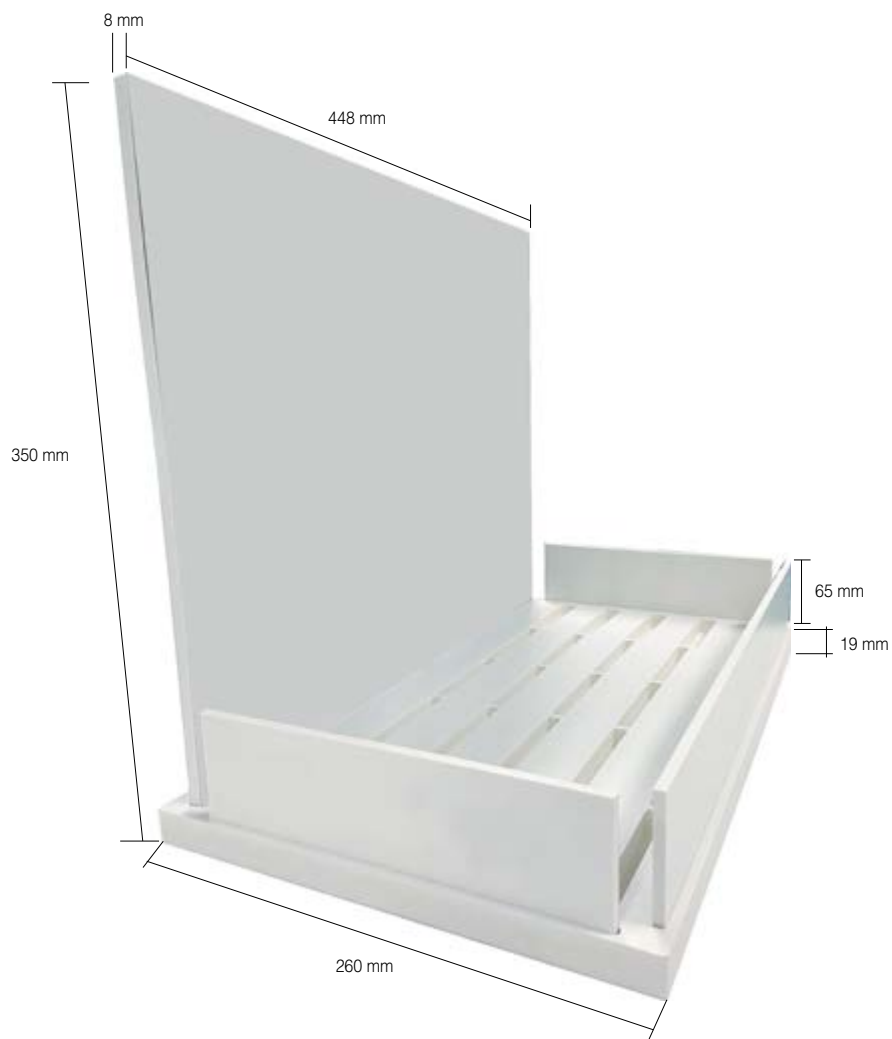

BASE SOBREMESA 25 RANURAS

RANURAS	FORMATO (cm)	PESO (kg)	MATERIALES
25	8x8x1,2	2,2	PVC

OPCIONES:

Logo de empresa en vinilo de corte o impresión directa

Fabricación Propia



BASE SOBREMESA

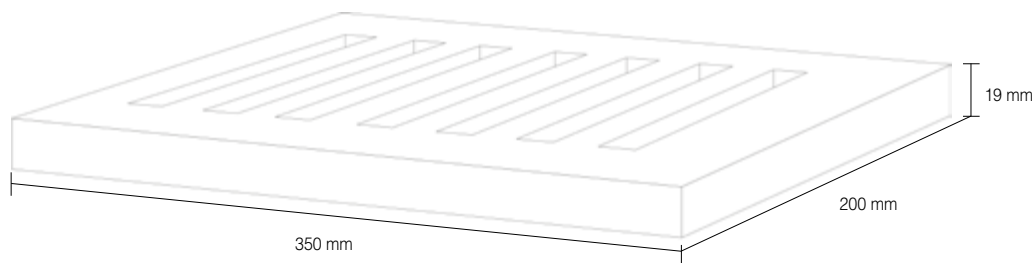

BASE SOBREMESA 7 RANURAS

RANURAS	FORMATO (cm)	PESO (kg)	MATERIALES
7	350x200x19	1,5	PVC

OPCIONES:

Logo de empresa en vinilo de corte o impresión directa

Fabricación Propia



BASE SOBREMESA

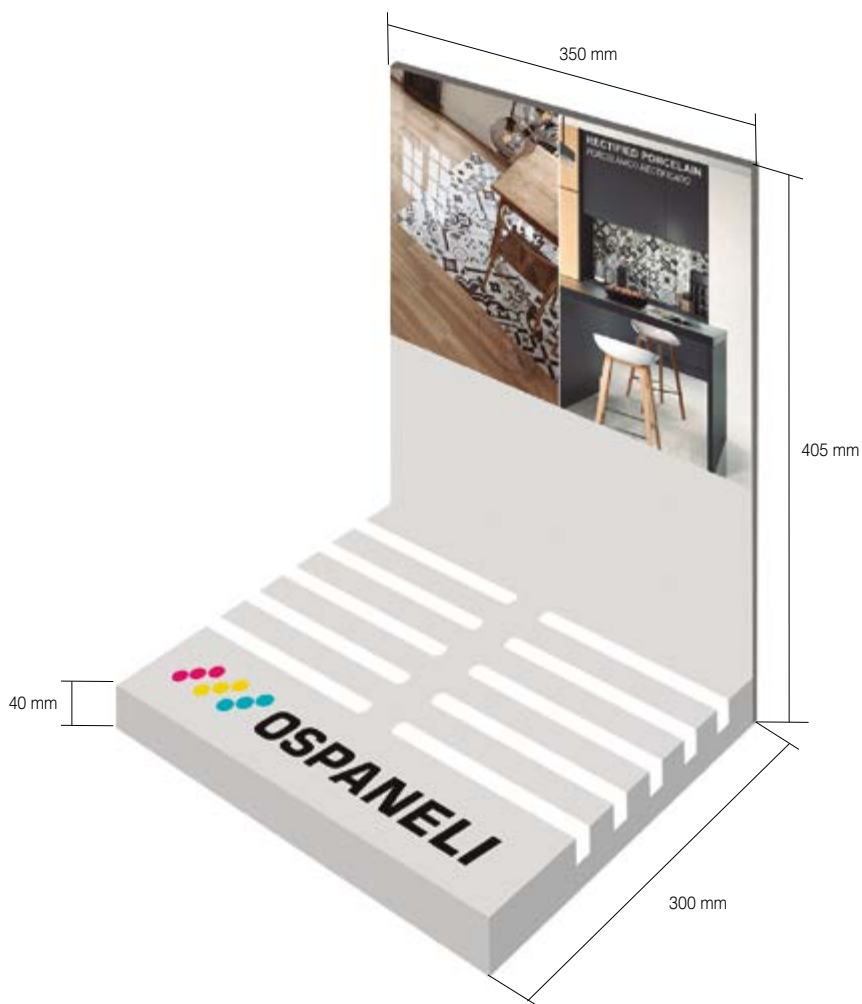

BASE HIDRAULICO

RANURAS	FORMATO (cm)	PESO (KG)	MATERIALES
10	20X20X1,1	2,5	DM / PVC

OPCIONES:

Logo de empresa en vinilo de corte o impresión directa
Cajón de madera opcional

Fabricación Propia



BASE SOBREMESA

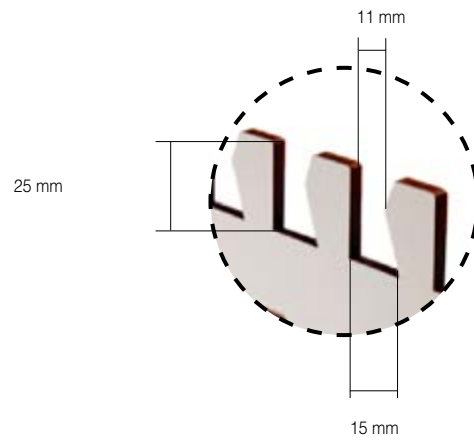

PORTAPIEZAS SOBREMESA CON TRASERA

RANURAS	FORMATO (cm)	PESO (kg)	MATERIAL
6	VARIOS	1	DM

OPCIONES:

Logo de empresa en vinilo de corte o impresión directa

Fabricación Propia



OSPA
N
E

BASE SUELO

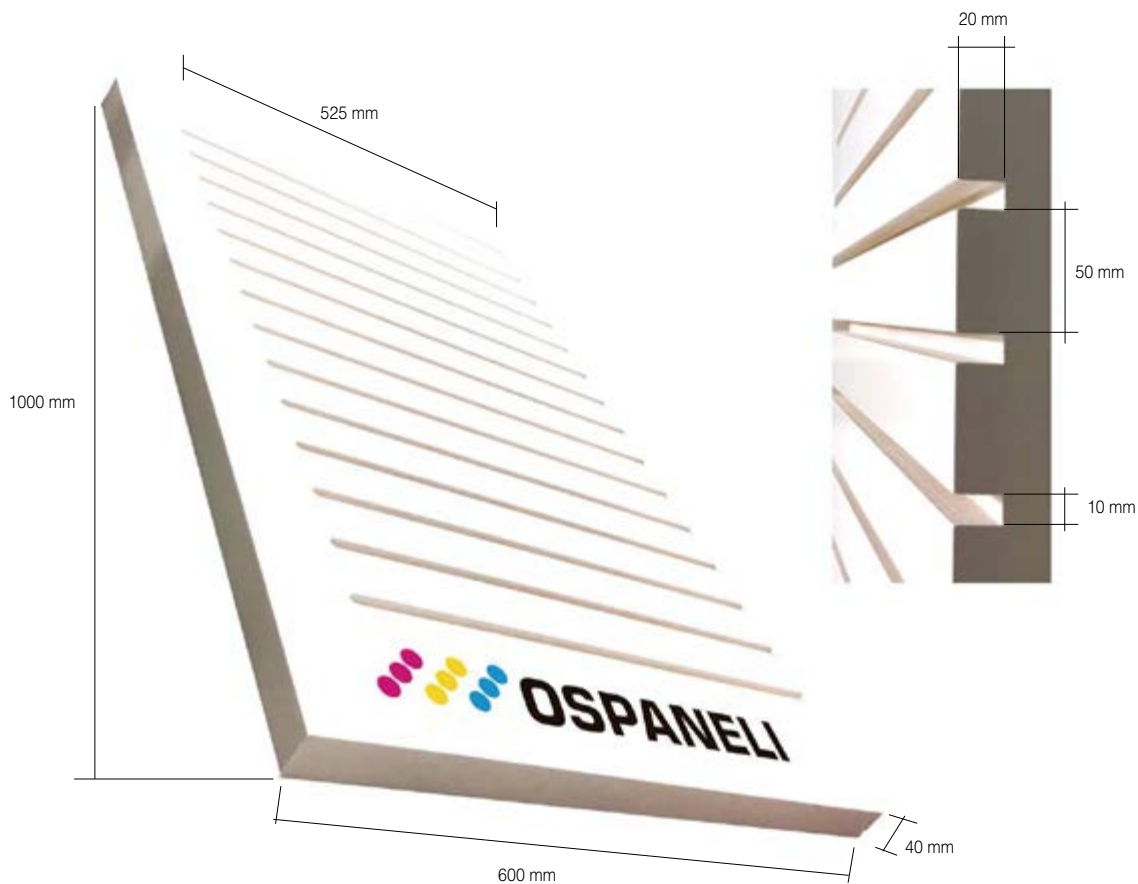

XXL

RANURAS	FORMATO (cm)	PESO (kg)	MATERIAL
14	VARIOS	17	DM

Fabricación Propia



OPCIONES:

Logo de empresa en vinilo de corte o impresión directa



CAJAS
CAJONES
expositores

CAJA MUESTRAS

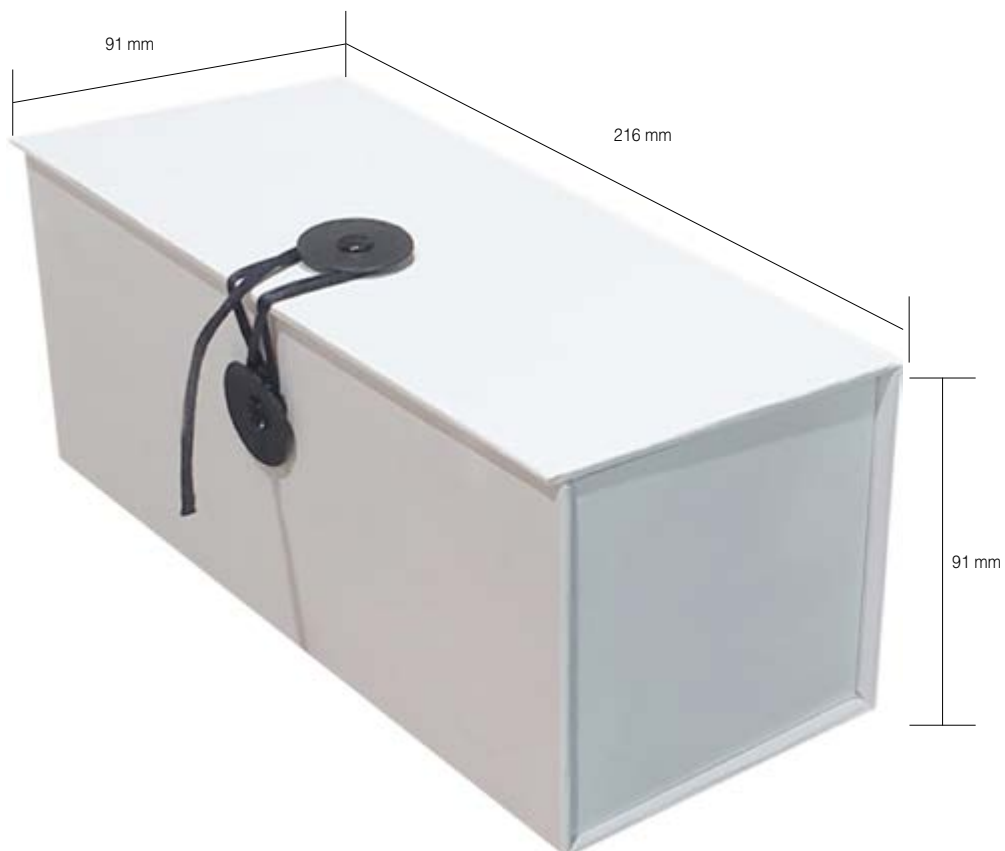

CAJA MUESTRAS CIERRE CHINO

FORMATO (cm)	PESO (kg)	MATERIALES
21,6x9,1x9,1	0,1	CARTÓN / METAL / POLIESTER

Fabricación Propia



OPCIONES:

Impresión gráfica

CAJA MUESTRAS

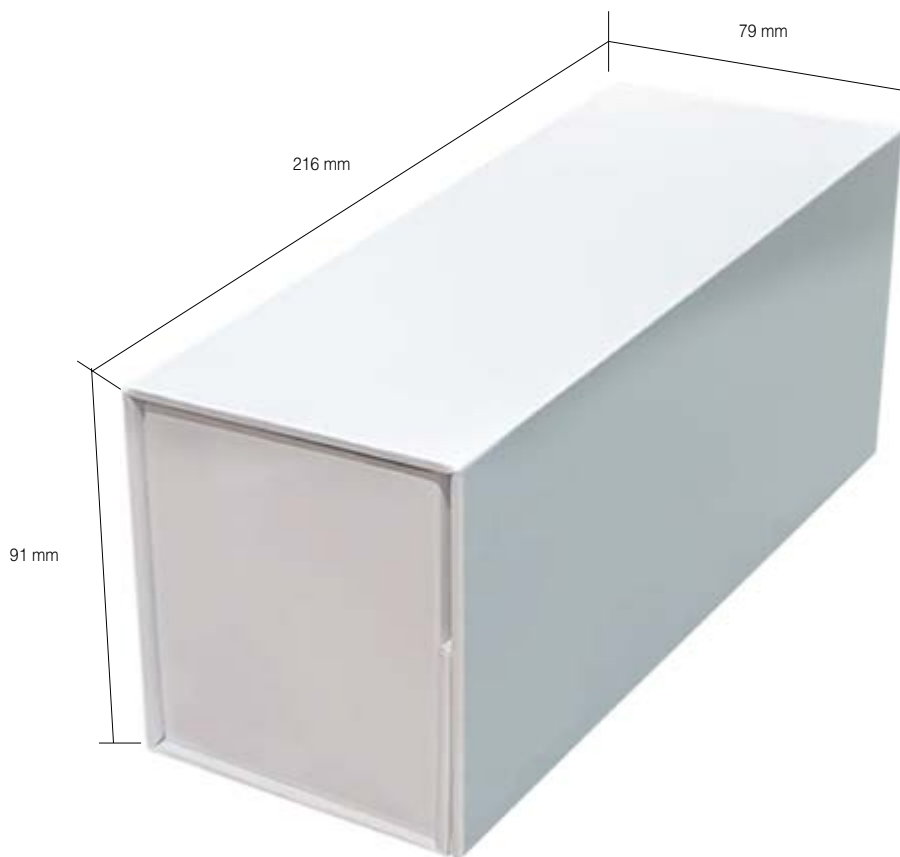

CAJA MUESTRAS CIERRE IMANTADO

FORMATO (cm)
21,6x9,1x7,9

PESO (kg)
0,1

MATERIALES
CARTÓN

Fabricación Propia



OPCIONES:

Impresión gráfica

CAJA MUESTRAS

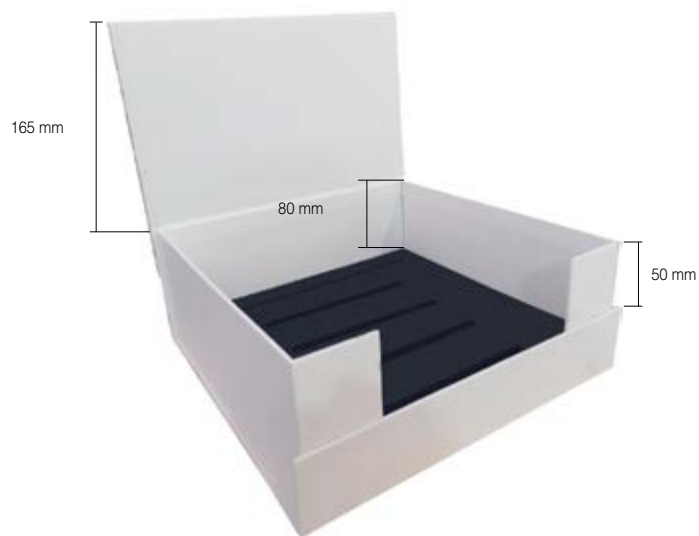
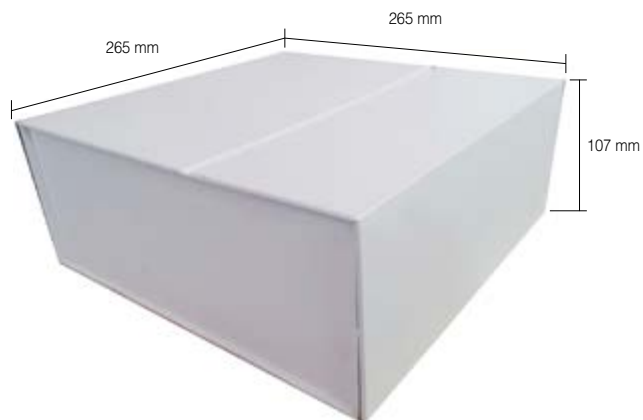

CAJA MUESTRAS CIERRE IMANTADO

RANURAS	FORMATO (cm)	PESO (KG)	MATERIALES
5	26,5x26,5x10,7	0,5	CARTÓN / ESPUMA

OPCIONES:

- Impresión gráfica
- Trasera Imantada
- Modificar ranuras interiores

Fabricación Propia



CAJA EMBALAJE

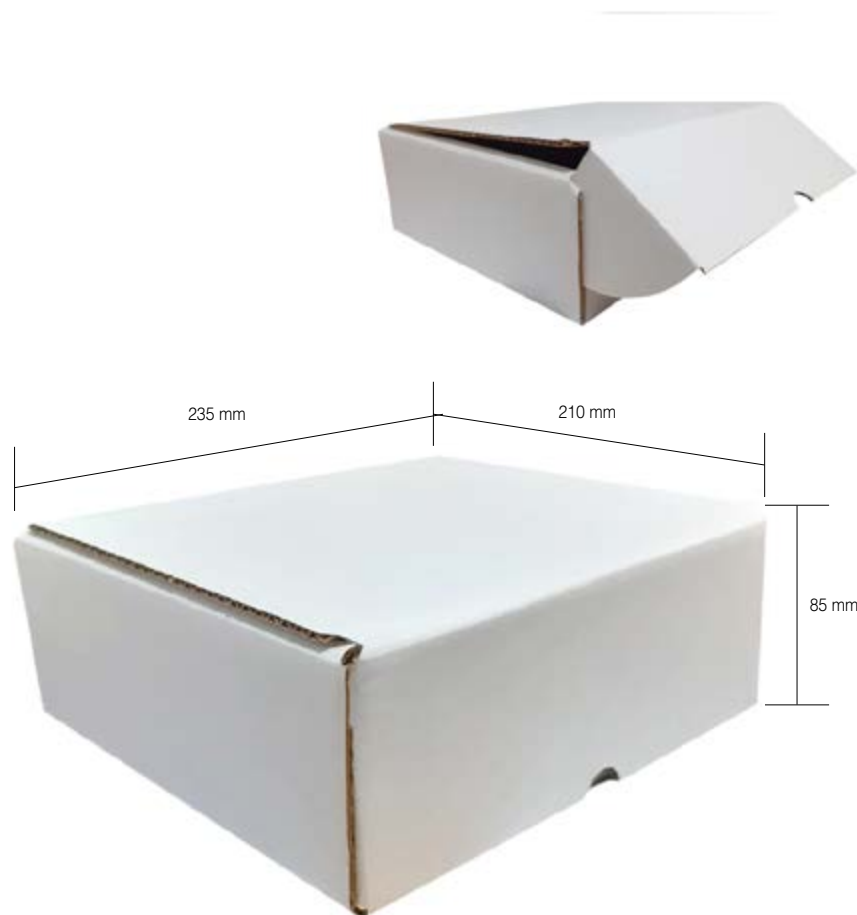

CAJA EMBALAJE CIERRE PESTAÑA

FORMATO (cm)	PESO (kg)	MATERIALES
23,5x21x8,5	0,1	CARTÓN

Fabricación Propia



OPCIONES:

Impresión directa

CAJA EMBALAJE

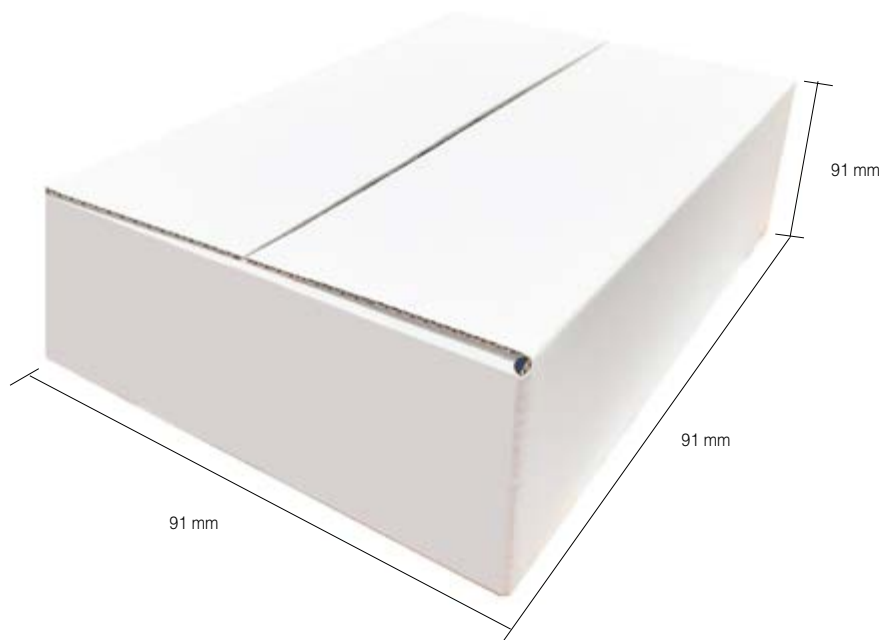

CAJA EMBALAJE CIERRE PRECINTO

FORMATO (cm)
21,6x9,1x7,9

PESO (kg)
0,1

MATERIALES
CARTÓN

Fabricación Propia



OPCIONES:

Impresión directa

CAJON MUESTRAS

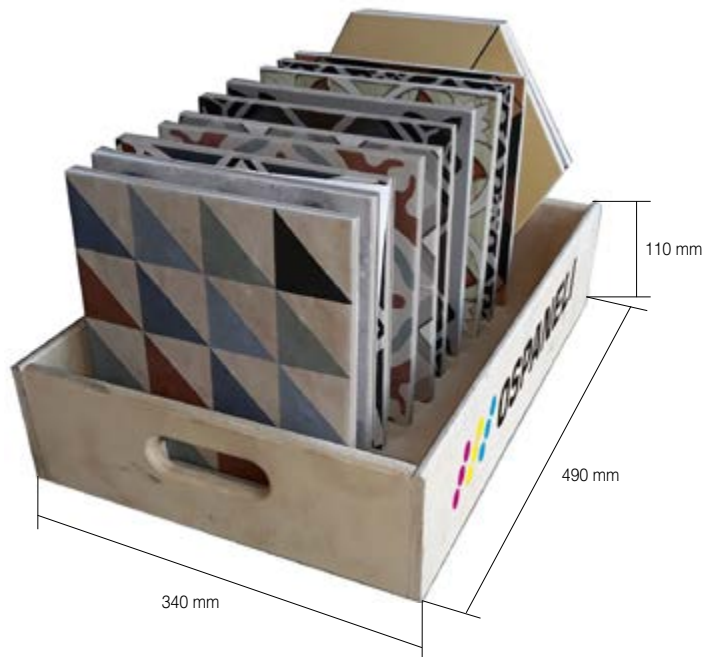

CAJON PORTAPIEZAS

RANURAS	FORMATO (cm)	PESO (Kg)
12	VARIOS	2

OPCIONES:

Impresión directa

Fabricación Propia



PANTOGRAFO



 **OSPANELI**

Tel: 964 60 53 30 / 667 741 357 / 691 655 089

gerencia@ondaservicios.es

www.ospaneli.es

The image features a dark grey background with a fine, repeating hexagonal pattern. Overlaid on this are several overlapping circles. A large, bright blue circle is the central focus, containing the text. To its upper right is a magenta circle, and to its lower right is a yellow-green circle. The circles have a slight transparency, allowing the background pattern to be visible through them.

CUNAS
muebles exposición

CUNA MADERA



MUNERATO DERECHA E IZQUIERDA

RANURAS	FORMATO (cm)	PESO (KG)
8	VARIOS	17

Fabricación Propia



OPCIONES:

Logo de empresa en vinilo de corte o impresión directa

CUNA MADERA



CUNA MADERAS

RANURAS	FORMATO (cm)	PESO (Kg)	MATERIALES
10	110x40x15	8	MADERA

Fabricación Propia



OPCIONES:

Logo de empresa en vinilo de corte o impresión directa

CUNA MADERA

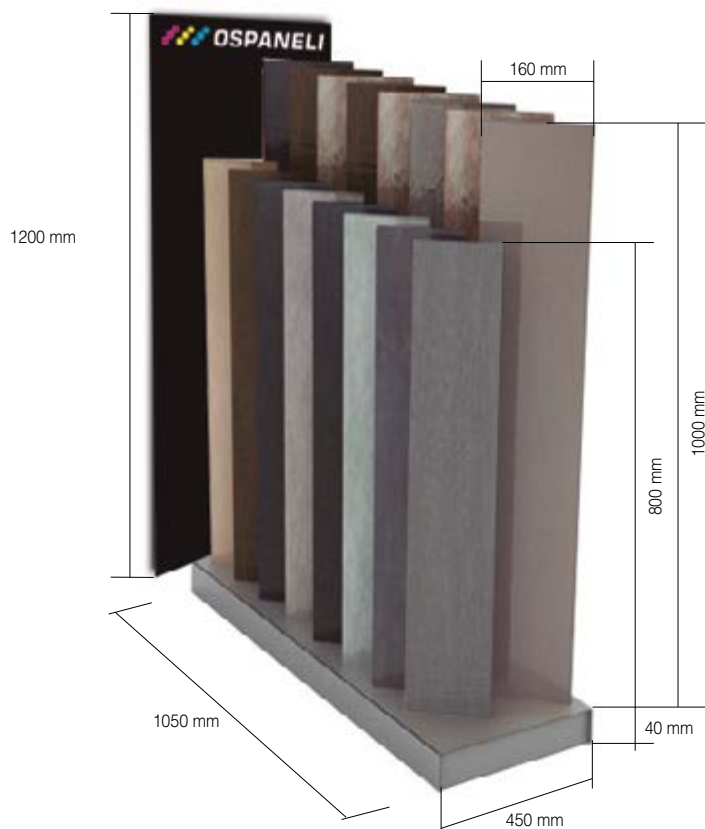

GRAND WOODS

RANURAS	FORMATO (cm)	PESO(Kg)	MATERIALES
10	VARIOS	8,5	HIERRO / MADERA
12	VARIOS	9	HIERRO / MADERA
14	VARIOS	9,5	HIERRO / MADERA
16	VARIOS	10	HIERRO / MADERA

OPCIONES:

Logo de empresa en vinilo de corte o impresión directa

Fabricación Propia



CUNA MADERA



10 PANELES

RANURAS	FORMATO (cm)	PESO (kg)	MATERIALES
10	610x1000	12	MADERA

Fabricación Propia



OPCIONES:

Logo de empresa en vinilo de corte o impresión directa

CUNA MADERA

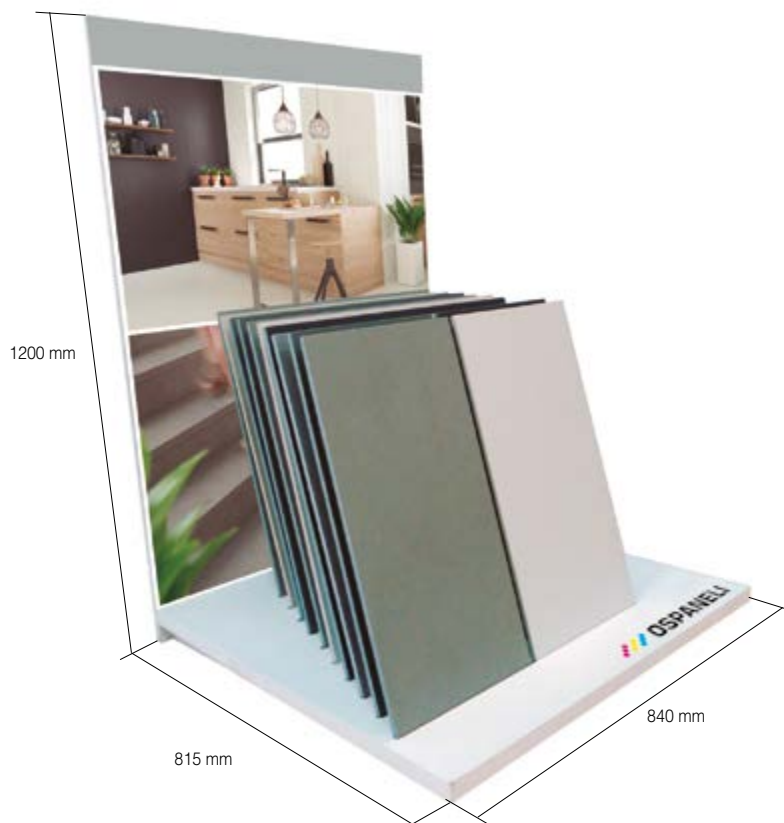

INCLINADA CON TRASERA

RANURAS
10
+ RANURAS

FORMATO (cm)
VARIOS
CONSULTAR

PESO (KG)
23

MATERIALES
MADERA

Fabricación Propia



OPCIONES:

Logo de empresa en vinilo de corte o impresión directa

CUNA MADERA

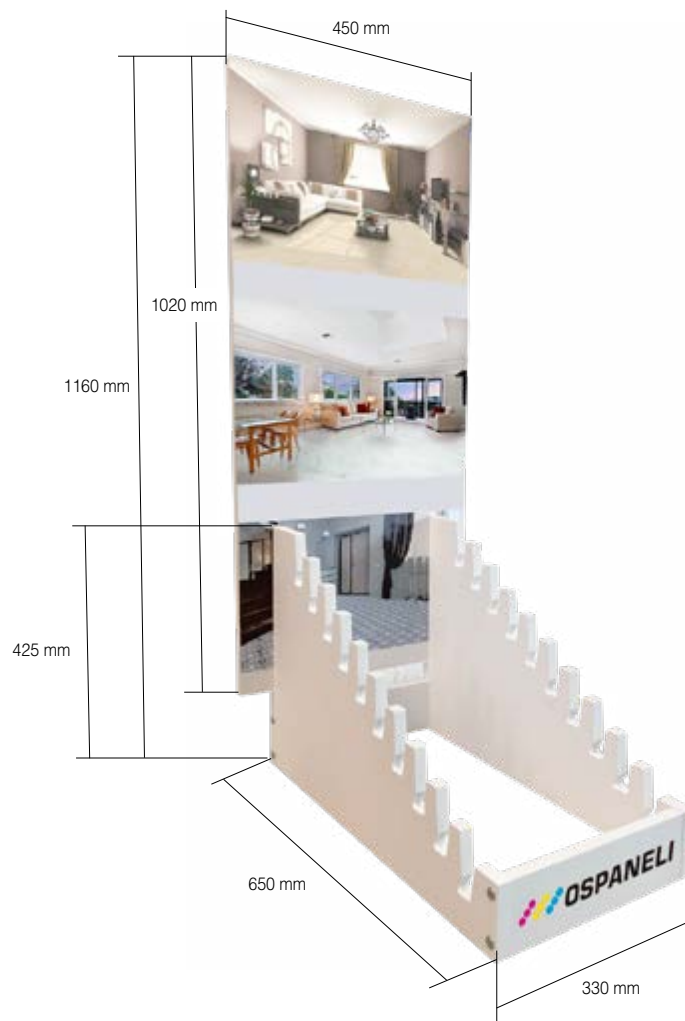

TOWER

RANURAS	FORMATO (cm)	PESO (Kg)	MATERIALES
6	100X120	10,5	MADERA
8	100X120		
10	100X120		
12	100X120		
14	100X120		

OPCIONES:

Logo de empresa en vinilo de corte o impresión directa

Fabricación Propia



CUNA MADERA

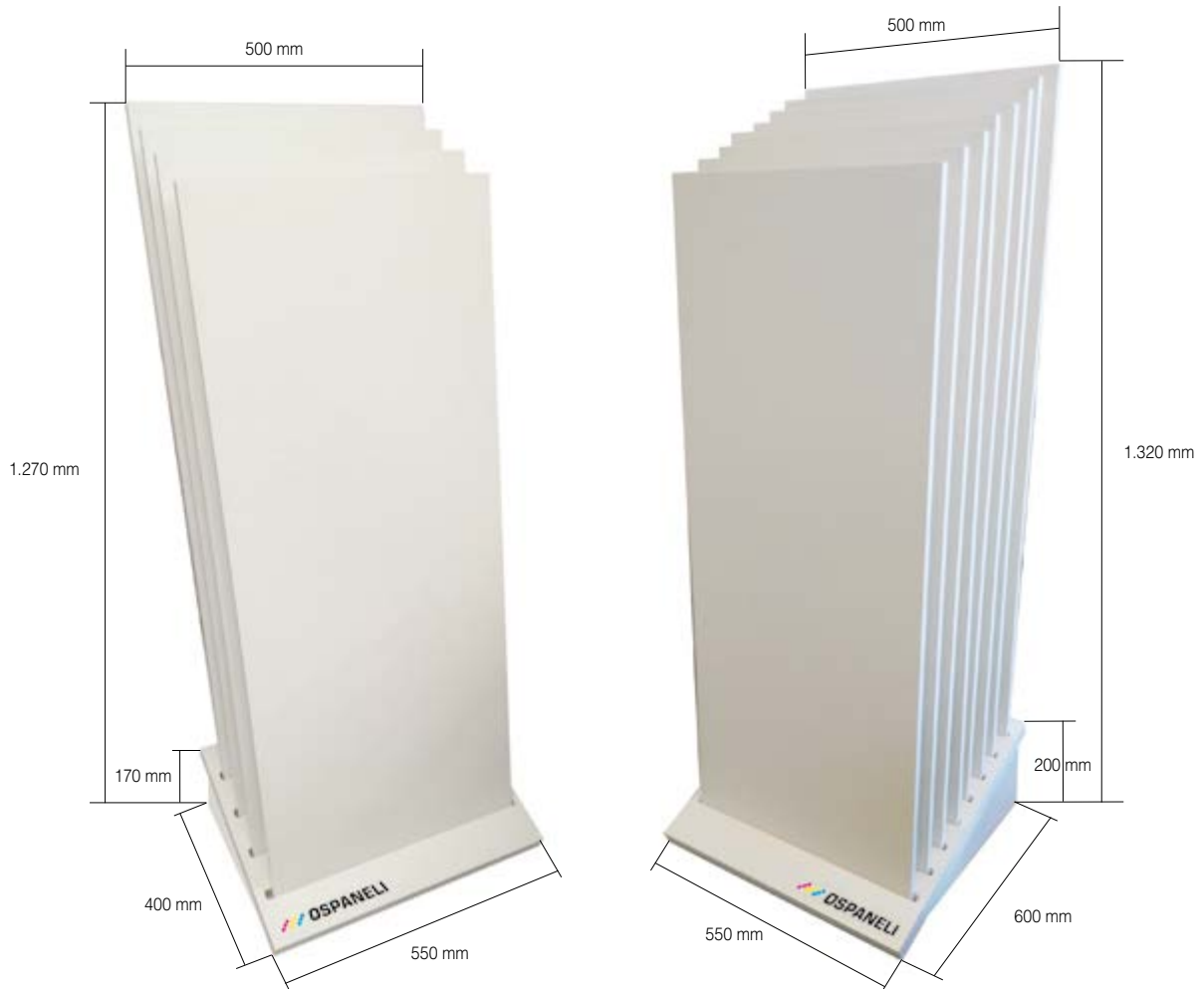

EDILIS Y STYLWOOD

RANURAS	FORMATO (cm)	PESO (Kg)*	MATERIALES
4	50x115	27	MADERA
8	50x115	50	MADERA
10	50x115	65	MADERA
12	50x115	70	MADERA

*Peso con paneles incluidos sin cerámica chapada

OPCIONES:

Logo de empresa en vinilo de corte o impresión directa

Fabricación Propia



CUNA METAL



MONTAN

RANURAS	FORMATO (cm)	PESO(Kg)*	MATERIALES
12 + 1 TRASERA BASE HIERRO	110 x 65	15	HIERRO GALBANIZADO

*Peso sin paneles

OPCIONES:

Logo de empresa troquelado

MADEL

RANURAS	FORMATO (cm)	PESO(Kg)*	MATERIALES
15 + 1 TRASERA	150 x 40	20	HIERRO / MELAMINA

*Peso sin paneles

OPCIONES:

Logo de empresa troquelado

CUNA METAL

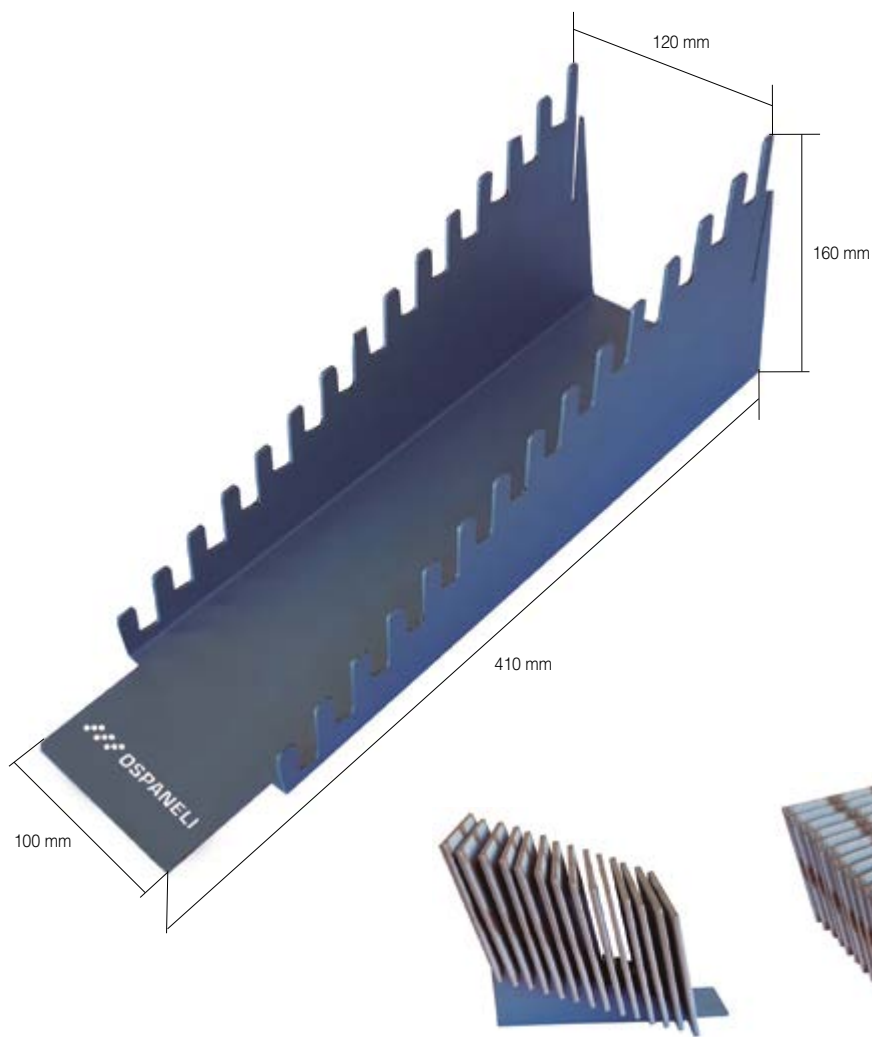

TOSCANA

RANURAS

8

15

FORMATO (cm)

VARIOS

VARIOS

PESO (Kg)

3

6,5

MATERIALES

ACERO GALBANIZADO

ACERO GALBANIZADO

Fabricación Propia



OPCIONES:

Logo de empresa en vinilo recortado o troquelado

COLORES DISPONIBLES



Negro



Antracita



Gris



Blanco

CUNA METAL

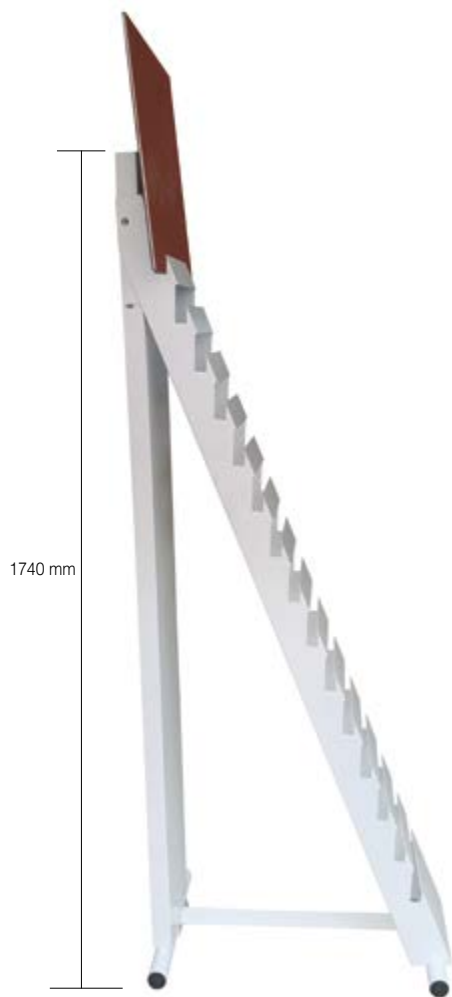

CASTOR

RANURAS	FORMATO (cm)	PESO(Kg)	MATERIALES
8	MULTIFORMATO	10,5	HIERRO
10	MULTIFORMATO	11,5	HIERRO
15	MULTIFORMATO	17	HIERRO

OPCIONES:

Logo de empresa en vinilo recortado o troquelado

Trasera de melamina de 19mm opcional

COLORES DISPONIBLES



Fabricación Propia



CUNA METAL

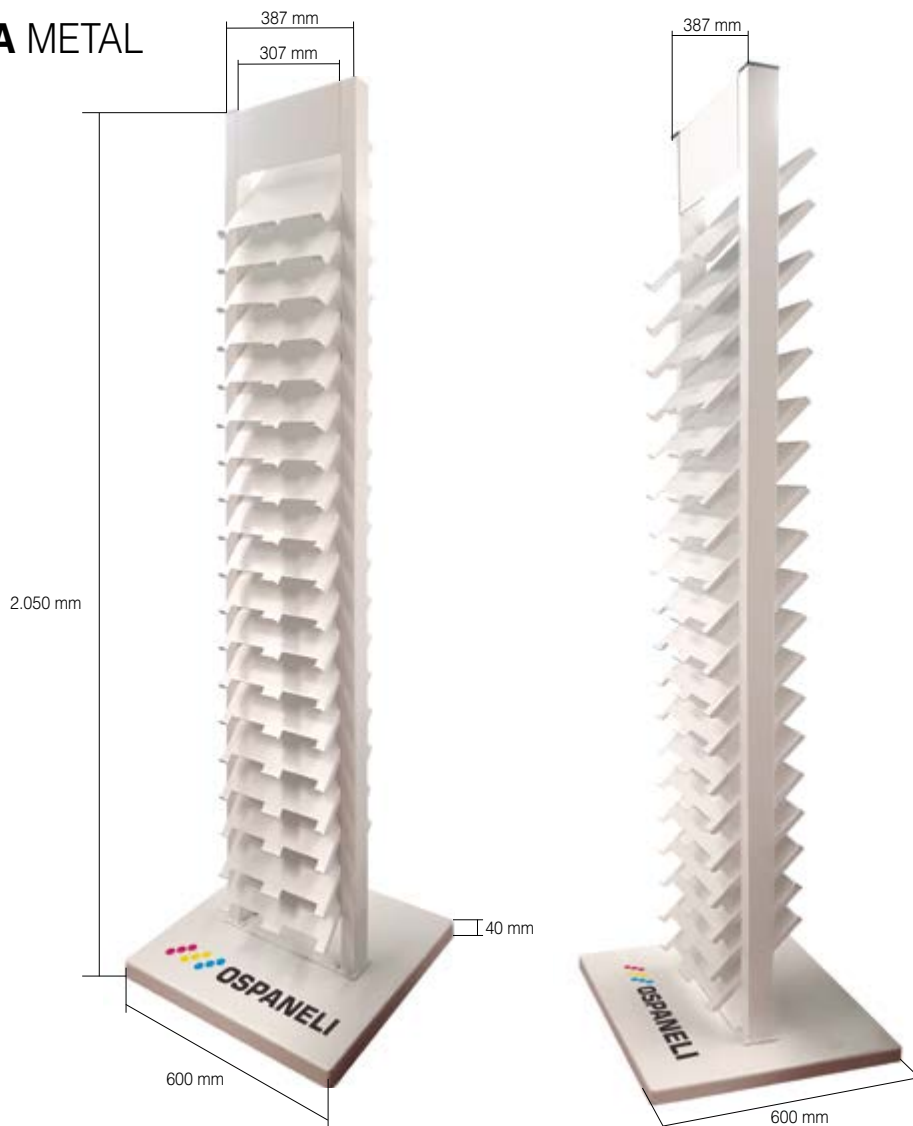

TORRE

RANURAS	FORMATO (cm)	PESO (kg)	MATERIALES
19	VARIOS	43	HIERRO

OPCIONES:

Logo de empresa en vinilo recortado o impresión directa

COLORES DISPONIBLES



Negro Antracita Gris Blanco

Fabricación Propia



CUNA METAL

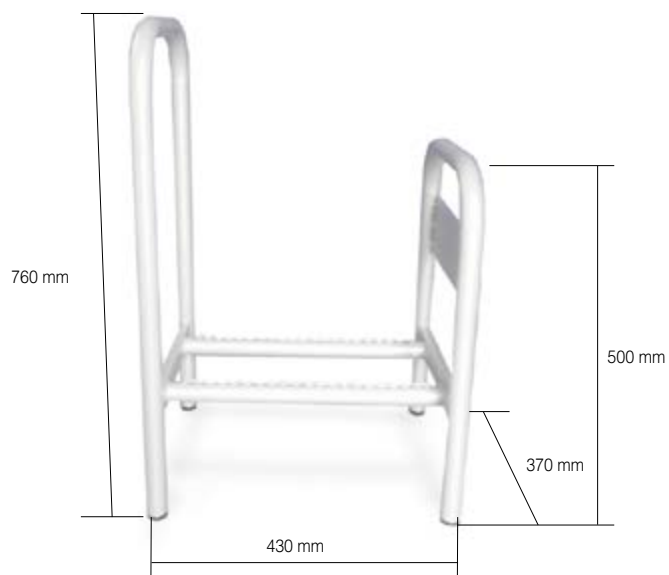

CUNA PANELES DE MANO

RANURAS	FORMATO (cm)	PESO (kg)	MATERIALES
15	MULTIFORMATO	10	HIERRO

OPCIONES:

Logo de empresa en vinilo recortado o troquelado

COLORES DISPONIBLES



Negro Antracita Gris Blanco

Fabricación Propia



CUNA METAL

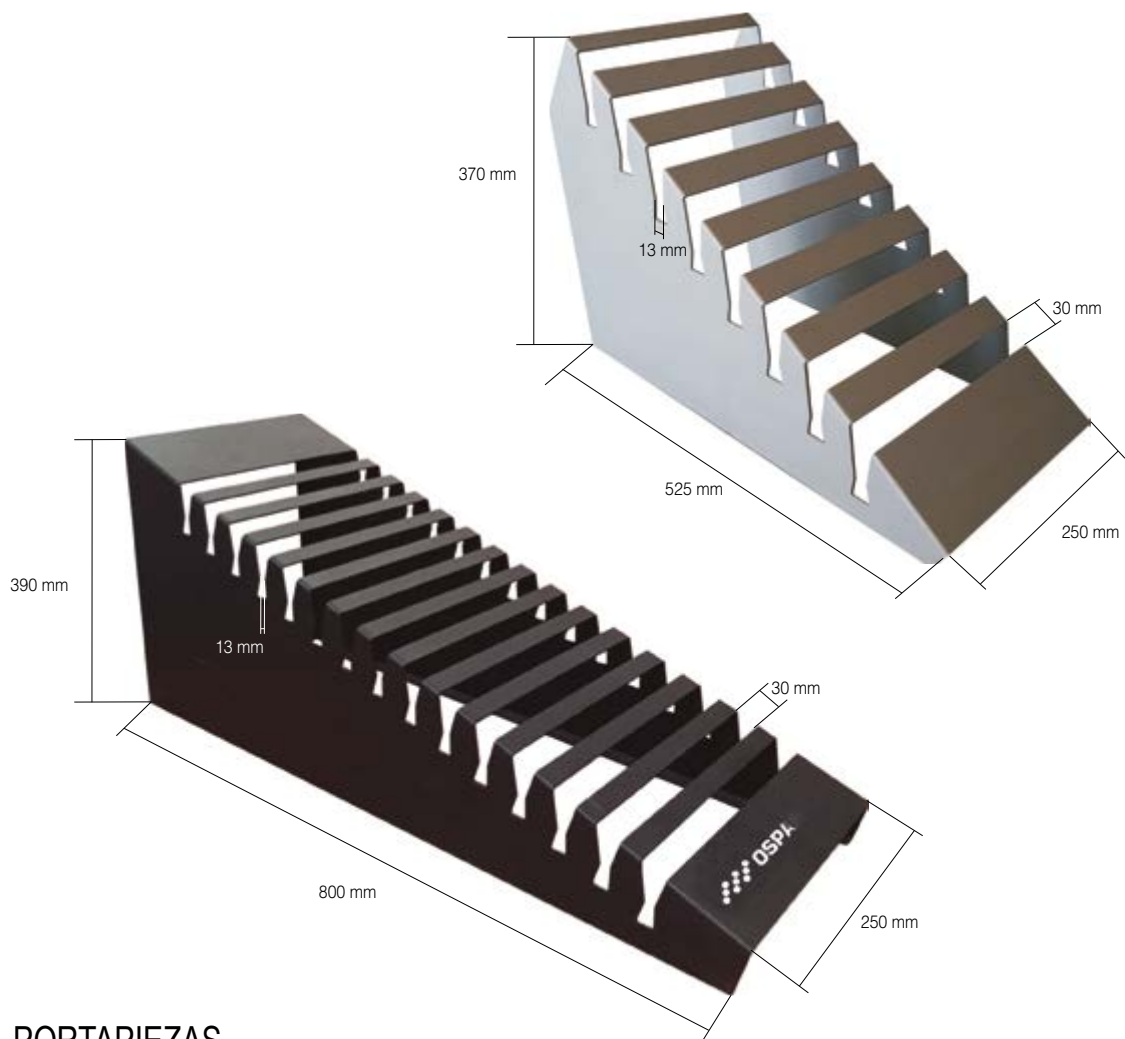

PORTAPIEZAS

RANURAS	FORMATO (cm)	PESO (Kg)	MATERIALES
6	VARIOS	2	HIERRO
8	VARIOS	3	HIERRO
10	VARIOS	4	HIERRO
15	VARIOS	6,5	HIERRO

OPCIONES:

Logo de empresa troquelado o vinilo recortado

COLORES DISPONIBLES



Negro Antracita Gris Blanco

Fabricación Propia





MUEBLES
paneles standar
piezas gran formato

CORTE LASER PARA HIERRO

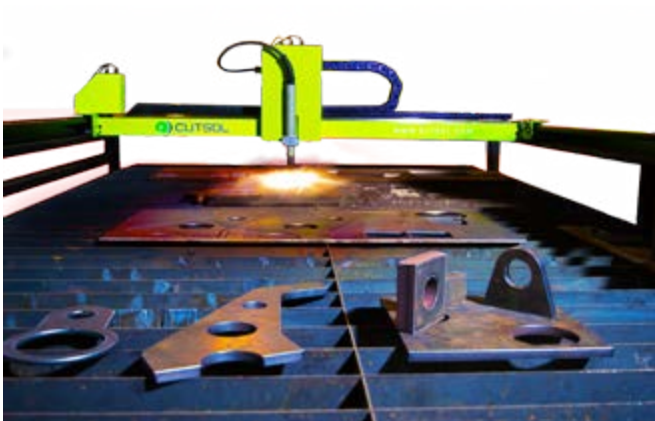

**MUEBLES PARA
GRAN FORMATO**

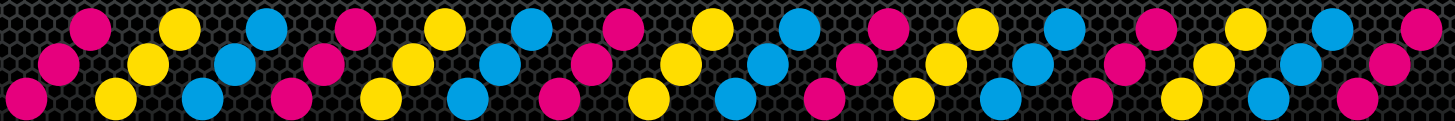

EXPOSITOR VERTICAL

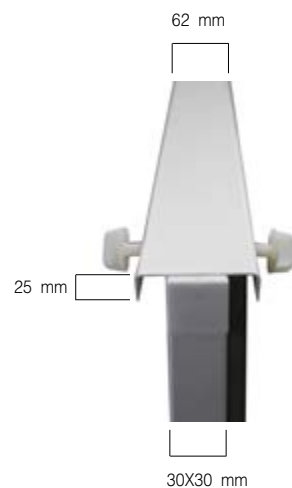

Grosor de pieza de 13 mm
Chapa de base de 3mm

PIE METAL 2P

Nº PIEZAS	FORMATO (cm)	PESO (kg)	MATERIALES
2	120 x 120	31	HIERRO
2	80 x 160	31	HIERRO

OPCIONES:

Logo de empresa en vinilo recortado

Puede personalizarse para cualquier formato de pieza

COLORES DISPONIBLES



Negro Antracita Gris Blanco

Fabricación Propia



MUEBLE GIRATORIO



EXTRAIBLE GIRATORIO CON IMANES

PANELES EXTRAÍBLES

5 (x 2 Piezas)
5 (x 2 Piezas)
5 (x 2 Piezas)
5 (x 2 Piezas)
5 (x 2 Piezas)
5 (x 2 Piezas)
5 (x 2 Piezas)
5 (x 2 Piezas)

FORMATO (cm)

45x118
60x120
75x75
90x90
100x100
120x120
80x160
80x80

PESO(Kg)

X
80
44
44
58
63
64
46

MATERIALES

HIERRO
HIERRO
HIERRO
HIERRO
HIERRO
HIERRO
HIERRO
HIERRO

CAJON DE MADERA INCLUIDO

OPCIONES:

Logo de empresa en vinilo recortado

Puede personalizarse con los formatos de piezas que se desee

Consultar posibilidad de cambiar número de carros

Puede servirse integrado en un cajon de melamina canteada

COLORES DISPONIBLES



Negro Antracita Gris Blanco

Fabricación Propia



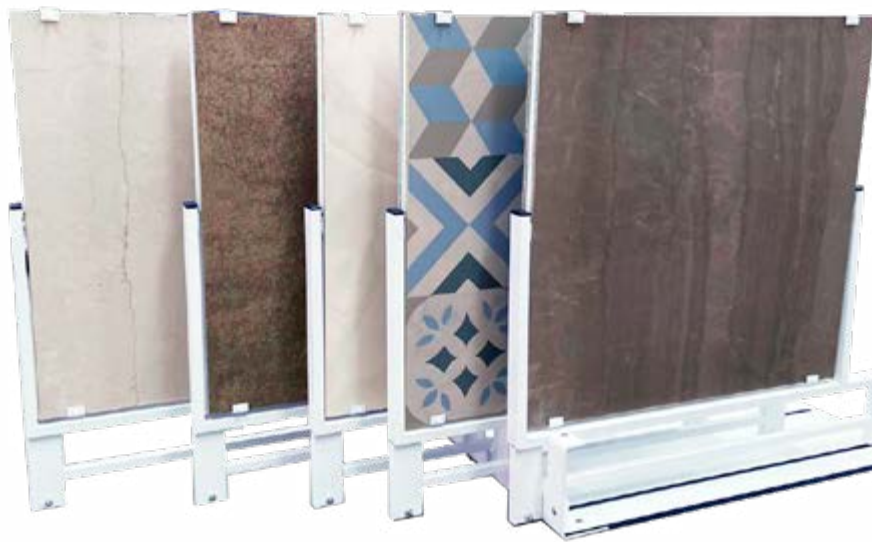

80x160 60X120 75X75 90X90 80X80 100X100 120x120



**MUEBLES EXTRAIBLES GIRATORIOS
PARA TODO TIPO DE FORMATOS**

MUEBLE VERTICAL



EXTRAIBLE SIMPLE* / DOBLE

Nº PANELES	FORMATO PANEL (cm)	DIMENSIONES (cm)	PESO (Kg)*	MATERIALES
5	192,5 x 100,5	222 x 42 x 132	230	HIERRO
5 DOBLE	192,5 x 100,5	222 x 61 x 132	300	HIERRO
12	192,5 x 120,0	222 x 42 x 158	330	HIERRO
6 DOBLE	192,5 x 120,0	222 x 61 x 158	400	HIERRO

KIT DE ILUMINACION OPCIONAL

COLORES DISPONIBLES



Negro Antracita Gris Blanco

Fabricación Propia



*Peso sin paneles

*En el modelo Simple el mueble puede abrirse hacia la derecha o izquierda

MUEBLE VERTICAL



EXTRAIBLE 10 DOBLE Y 15 DOBLE

Nº PANELES	FORMATO PANEL (cm)	DIMENSIONES (cm)	PESO (Kg) *	MATERIALES
10 DOBLE	192,5 x 100,5	222 x 113 x 132	410	HIERRO
15 DOBLE	192,5 x 100,5	222 x 165 x 132	610	HIERRO
10 DOBLE	192,5 x 120,0	222 x 113 x 158	490	HIERRO
15 DOBLE	192,5 x 120,0	222 x 265 x 158	730	HIERRO

KIT DE ILUMINACION OPCIONAL

COLORES DISPONIBLES



Fabricación Propia



*Peso sin paneles

MUEBLE VERTICAL

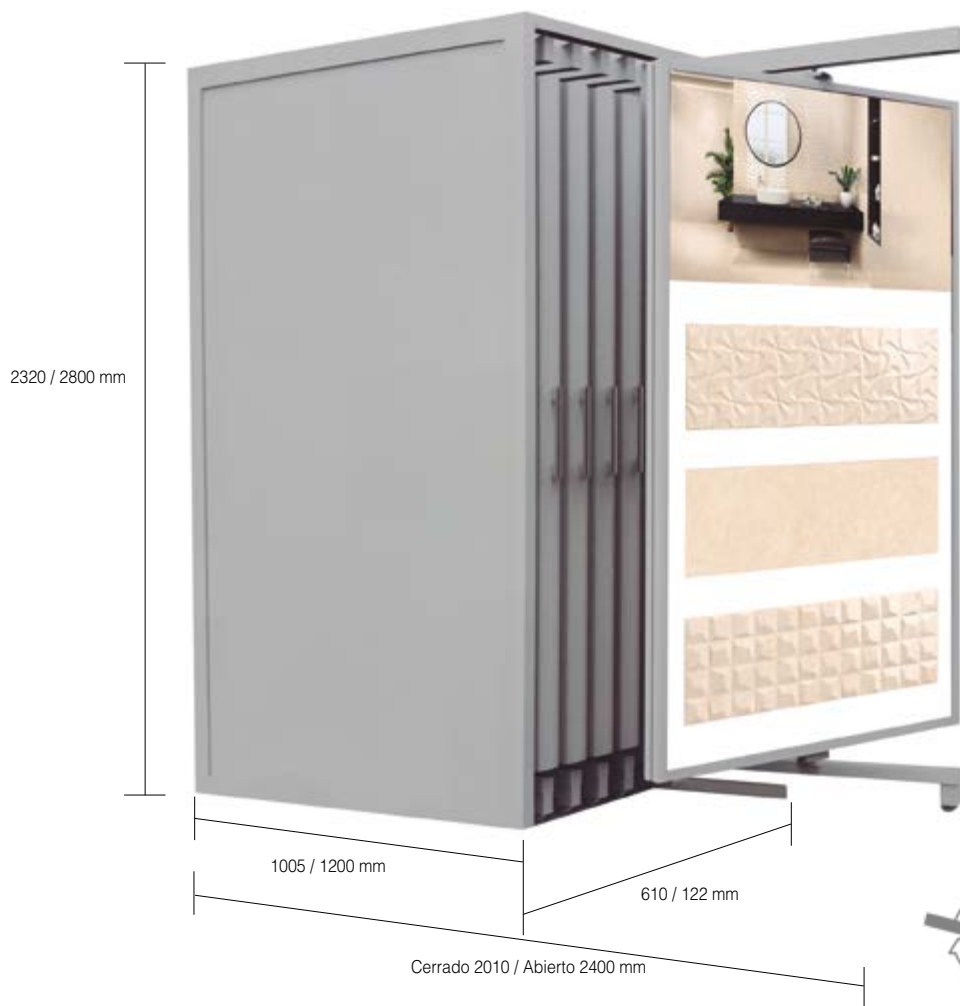

EXTRAIBLE GIRATORIO

Nº PANELES	FORMATO PANEL (cm)	DIMENSIONES (cm)	PESO (Kg)*	MATERIALES
5 DOBLE	192,5 x 100,5	232x61x132	320	HIERRO
5 DOBLE	240,0 x 120,0	280x61x132	382	HIERRO
10 DOBLE	192,5 x 100,5	232x122x132	590	HIERRO
10 DOBLE	240,0 x 120,0	280x122x132	590	HIERRO

CAJON DE MADERA INCLUIDO

COLORES DISPONIBLES



Fabricación Propia



*Peso sin paneles

MUEBLE VERTICAL



SILVIA

Fabricación Propia



Nº PANELES	FORMATO PANEL (cm)	DIMENSIONES (cm)	PESO (Kg)*	MATERIALES
10 DOBLE	192,5 x 100,5	230 x 317 x 110	430	HIERRO
12 DOBLE	192,5 x 100,5	230 x 317 x 110	442	HIERRO

KIT DE ILUMINACION INCLUIDO

*Peso sin paneles

COLORES DISPONIBLES



MUEBLE VERTICAL



SIN TECHO SIMPLE

Nº PANELES	FORMATO PANEL (cm)	DIMENSIONES (cm)	PESO (Kg)*	MATERIALES
10+2	192,5 x 100,5	212 x 222 x 130	310	HIERRO
12+2	192,5 x 100,5	212 x 222 x 140	442	HIERRO
15+2	192,5 x 100,5	212 x 222 x 150	474	HIERRO
10+2	192,5 x 120,0	212 x 265 x 130	370	HIERRO
12+2	192,5 x 120,0	212 x 265 x 140	528	HIERRO
15+2	192,5 x 120,0	212 x 265 x 150	566	HIERRO

KIT DE ILUMINACION OPCIONAL

COLORES DISPONIBLES



Fabricación Propia



*Peso sin paneles

MUEBLE VERTICAL



SIN TECHO DOBLE

Nº PANELES	FORMATO PANEL (cm)	DIMENSIONES (cm)	PESO (Kg) *	MATERIALES
20+3	192,5 x 100,5	212 x 335 x130	710	HIERRO
24+3	192,5 x 100,5	212 x 335 x140	742	HIERRO
30+3	192,5 x 100,5	212 x 335 x150	774	HIERRO
20+3	192,5 x 120,0	212 x 395 x130	848	HIERRO
24+3	192,5 x 120,0	212 x 395 x140	886	HIERRO
30+3	192,5 x 120,0	212 x 395 x150	924	HIERRO

KIT DE ILUMINACION OPCIONAL

COLORES DISPONIBLES



Fabricación Propia



*Peso sin paneles

MUEBLE VERTICAL



ELIA

Fabricación Propia

Nº PANELES	FORMATO PANEL (cm)	DIMENSIONES (cm)	PESO (Kg) *	MATERIALES
10 DOBLE	192,5 x 100,5	250 x 340 x 125	450	HIERRO
12 DOBLE	192,5 x 100,5	250 x 340 x 135	474	HIERRO

KIT DE ILUMINACION OPCIONAL

*Peso sin paneles

COLORES DISPONIBLES



MUEBLE VERTICAL

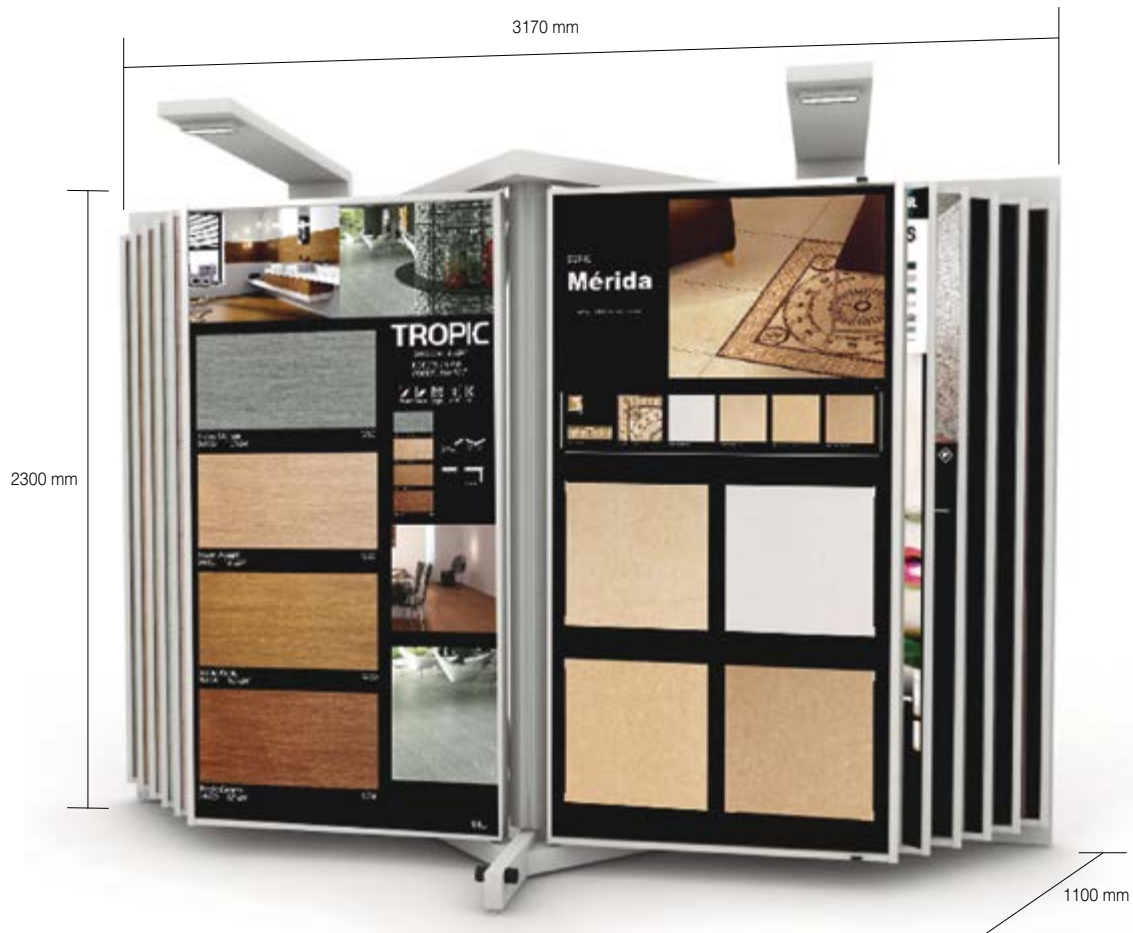

F22 y F26

Fabricación Propia

Nº PANELES	FORMATO PANEL (cm)	DIMENSIONES (cm)	PESO (Kg) *	MATERIALES
10 DOBLE + 2	192,5 x 100,5	230 x 317 x 110	430	HIERRO
12 DOBLE + 2	192,5 x 100,5	230 x 317 x 110	454	HIERRO



KIT DE ILUMINACION OPCIONAL

*Peso sin paneles

COLORES DISPONIBLES



MUEBLE VERTICAL



MONACO

Fabricación Propia

Nº PANELES

12 DOBLE

FORMATO PANEL (cm)

192,5 x 100,5

DIMENSIONES (cm)

235 x 308 x 118

PESO (Kg)*

410

MATERIALES

HIERRO



KIT DE ILUMINACION OPCIONAL

*Peso sin paneles

COLORES DISPONIBLES



Negro Antracita Gris Blanco

MUEBLE VERTICAL



ARGEL

Fabricación Propia

Nº PANELES	FORMATO PANEL (cm)	DIMENSIONES (cm)	PESO (Kg) *	MATERIALES
10 DOBLE	192,5 x 100,5	235 x 308 x 118	410	HIERRO
12 DOBLE	192,5 x 100,5	235 x 308 x 118	434	HIERRO

KIT DE ILUMINACION OPCIONAL

*Peso sin paneles

COLORES DISPONIBLES



MUEBLE VERTICAL



SEGRE

Fabricación Propia

Nº PANELES

14 DOBLE +2

FORMATO PANEL (cm)

192,5 x 100,5

DIMENSIONES (cm)

232 x 353 x 122

PESO (Kg)*

610

MATERIALES

HIERRO



KIT DE ILUMINACION OPCIONAL

*Peso sin paneles

COLORES DISPONIBLES



Negro



Antracita



Gris



Blanco

MUEBLE VERTICAL



L8 y L10

Fabricación Propia



Nº PANELES	FORMATO PANEL (cm)	DIMENSIONES (cm)	PESO (Kg)*	MATERIALES
8 DOBLE	192,5 x 100,5	230 x 180 x 112	310	HIERRO
10 DOBLE	192,5 x 100,5	230 x 180 x 112	360	HIERRO

KIT DE ILUMINACION OPCIONAL

*Peso sin paneles

COLORES DISPONIBLES



MUEBLE VERTICAL



TUNICIA SIMPLE

Fabricación Propia

Nº PANELES	FORMATO PANEL (cm)	DIMENSIONES (cm)	PESO (Kg) *	MATERIALES
10+2	192,5 x 100,5	232 x 229 x119	460	HIERRO
12+2	192,5 x 100,5	232 x 229 x129	492	HIERRO
15+2	192,5 x 100,5	232 x 229 x139	524	HIERRO

KIT DE ILUMINACION OPCIONAL

COLORES DISPONIBLES



*Peso sin paneles



MUEBLE VERTICAL



TUNICIA DOBLE

Fabricación Propia



Nº PANELES	FORMATO PANEL (cm)	DIMENSIONES (cm)	PESO (Kg) *	MATERIALES
20+3	192,5 x 100,5	232 x 340 x119	910	HIERRO
24+3	192,5 x 100,5	232 x 340 x129	942	HIERRO
30+3	192,5 x 100,5	232 x 340 x139	974	HIERRO

KIT DE ILUMINACION OPCIONAL

COLORES DISPONIBLES



*Peso sin paneles

MUEBLE VERTICAL

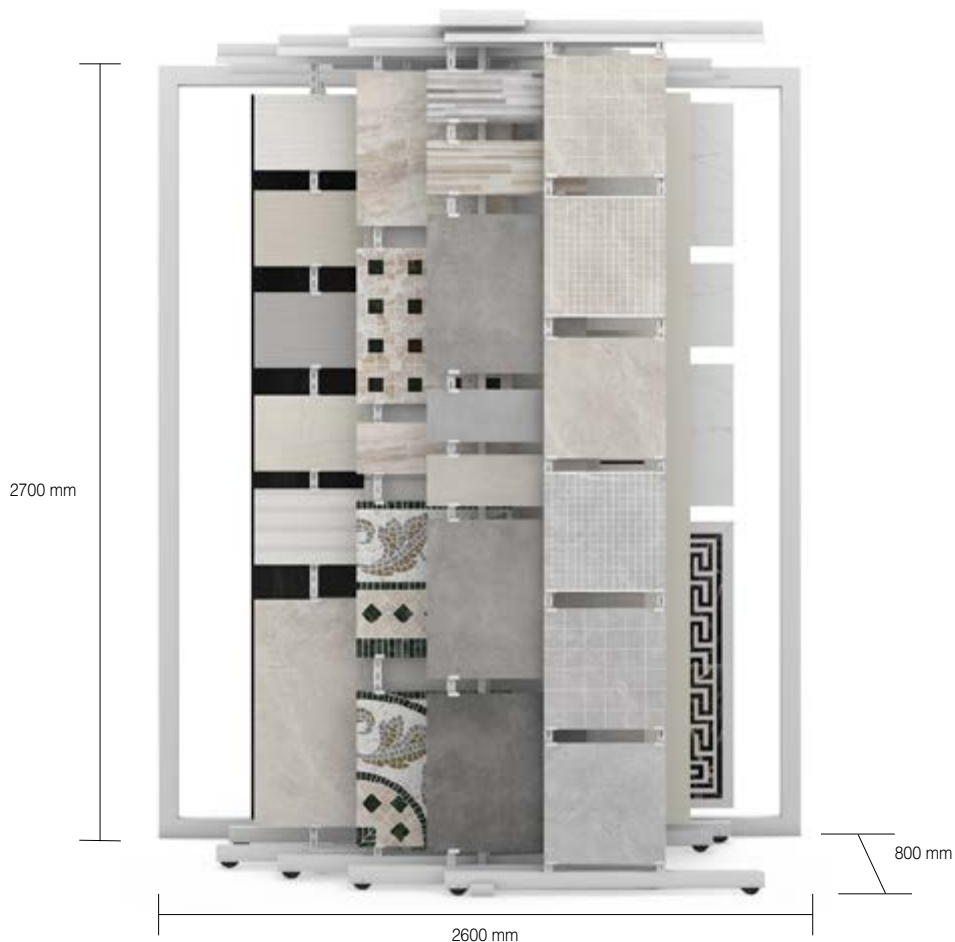

SIN TECHO TECNICO MULTIFORMATO

Fabricación Propia

Nº PANELES	FORMATO PANEL (cm)	DIMENSIONES (cm)	PESO (Kg)	MATERIALES
5	VARIOS	260 x 270 x 80	550	HIERRO

KIT DE ILUMINACION OPCIONAL

COLORES DISPONIBLES



MUEBLE HORIZONTAL

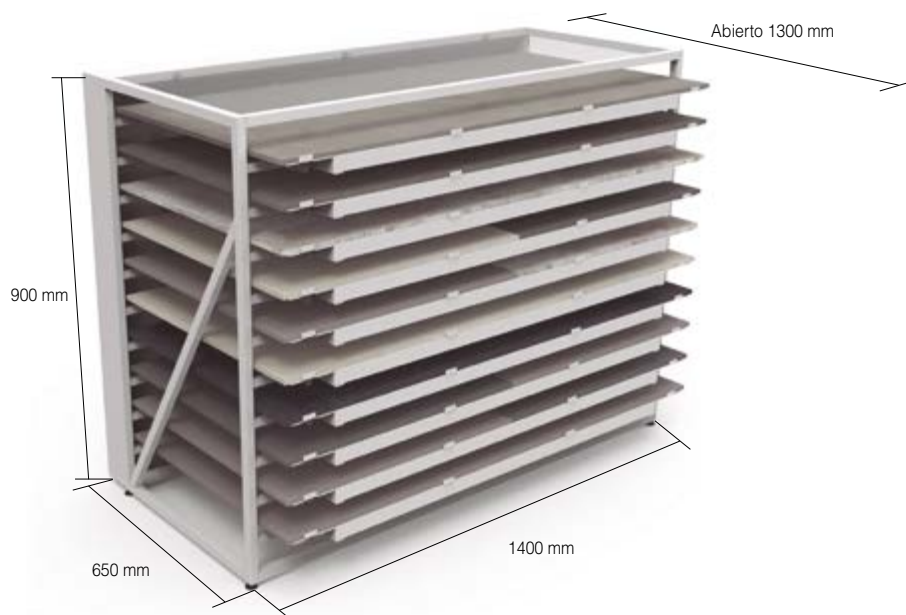

MESA EXTRAIBLE TIPO BANDEJA

BANDEJAS

10

FORMATO (cm)

60x120

MATERIALES

HIERRO

CAJON DE MADERA

COLORES DISPONIBLES



Negro



Antracita



Gris



Blanco

Fabricación Propia



MUEBLE HORIZONTAL

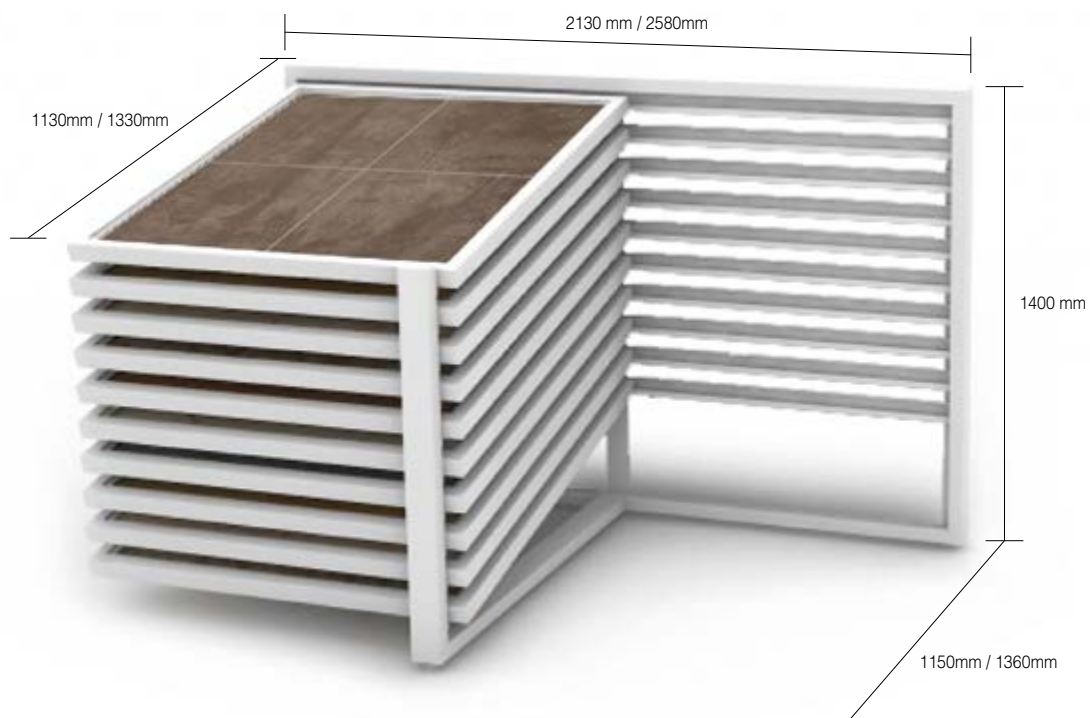

BERLIN SIMPLE

Fabricación Propia

Nº PANELES	FORMATO PANEL (cm)	DIMENSIONES (cm)	PESO (Kg)*	MATERIALES
10	100,5 x 100,5	140 x 213 x 113	410	HIERRO
10	120,5 x 120,5	140 x 258 x 133	460	HIERRO



*Peso sin cerámica

COLORES DISPONIBLES



MUEBLE HORIZONTAL



BERLIN DOBLE

Fabricación Propia

Nº PANELES	FORMATO PANEL (cm)	DIMENSIONES (cm)	PESO (Kg)*	MATERIALES
20	100,5 x 100,5	140 x 318 x 113	610	HIERRO
20	120,5 x 120,5	140 x 374 x 133	710	HIERRO



*Peso sin cerámica

COLORES DISPONIBLES



MUEBLE HORIZONTAL

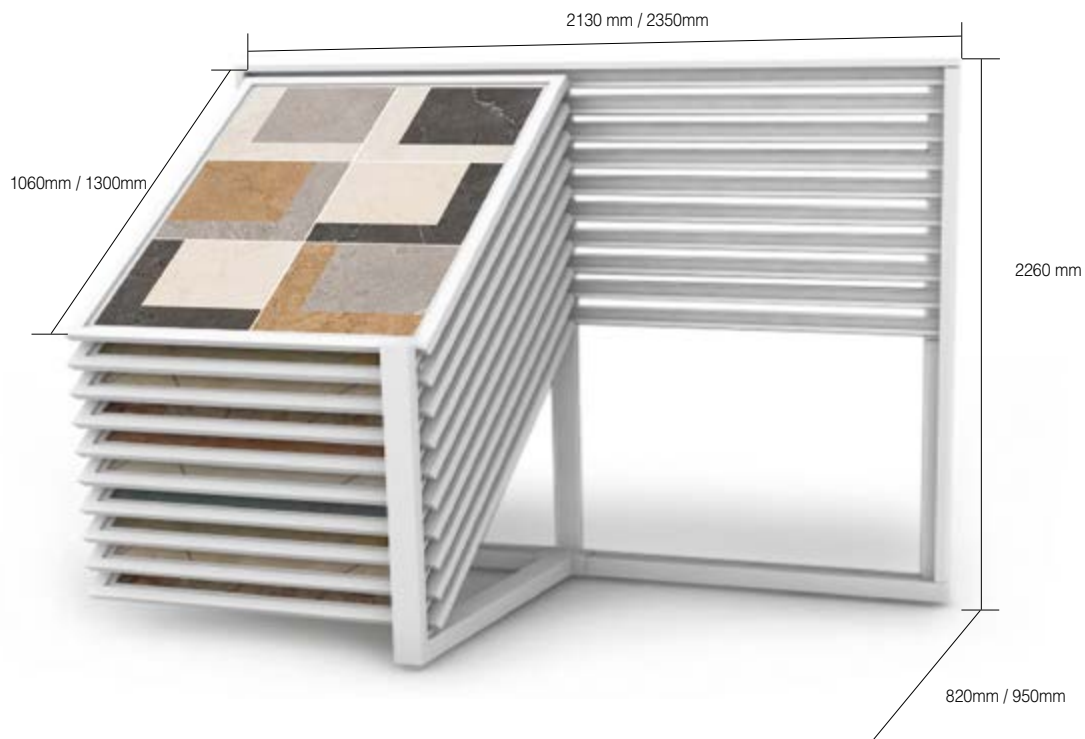

MUNICH SIMPLE

Fabricación Propia

Nº PANELES	FORMATO PANEL (cm)	DIMENSIONES (cm)	PESO (Kg)*	MATERIALES
10	100,5 x 100,5	226 x 213 x 106	410	HIERRO
10	120,5 x 120,5	226 x 235 x 130	460	HIERRO



*Peso sin cerámica

COLORES DISPONIBLES



MUEBLE HORIZONTAL

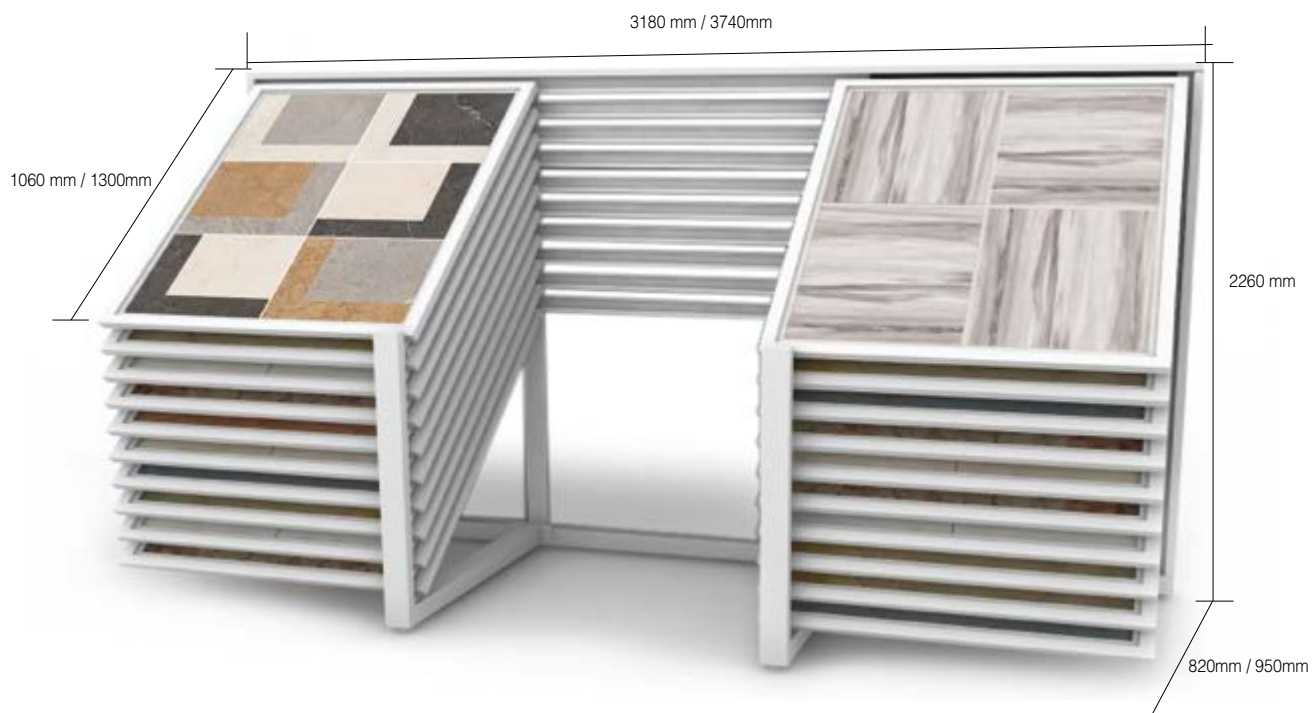

MUNICH DOBLE

Fabricación Propia

Nº PANELES	FORMATO PANEL (cm)	DIMENSIONES (cm)	PESO (Kg) *	MATERIALES
20	100,5 x 100,5	226 x 318 x 106	710	HIERRO
20	120,5 x 120,5	226 x 374 x 130	810	HIERRO



*Peso sin cerámica

COLORES DISPONIBLES



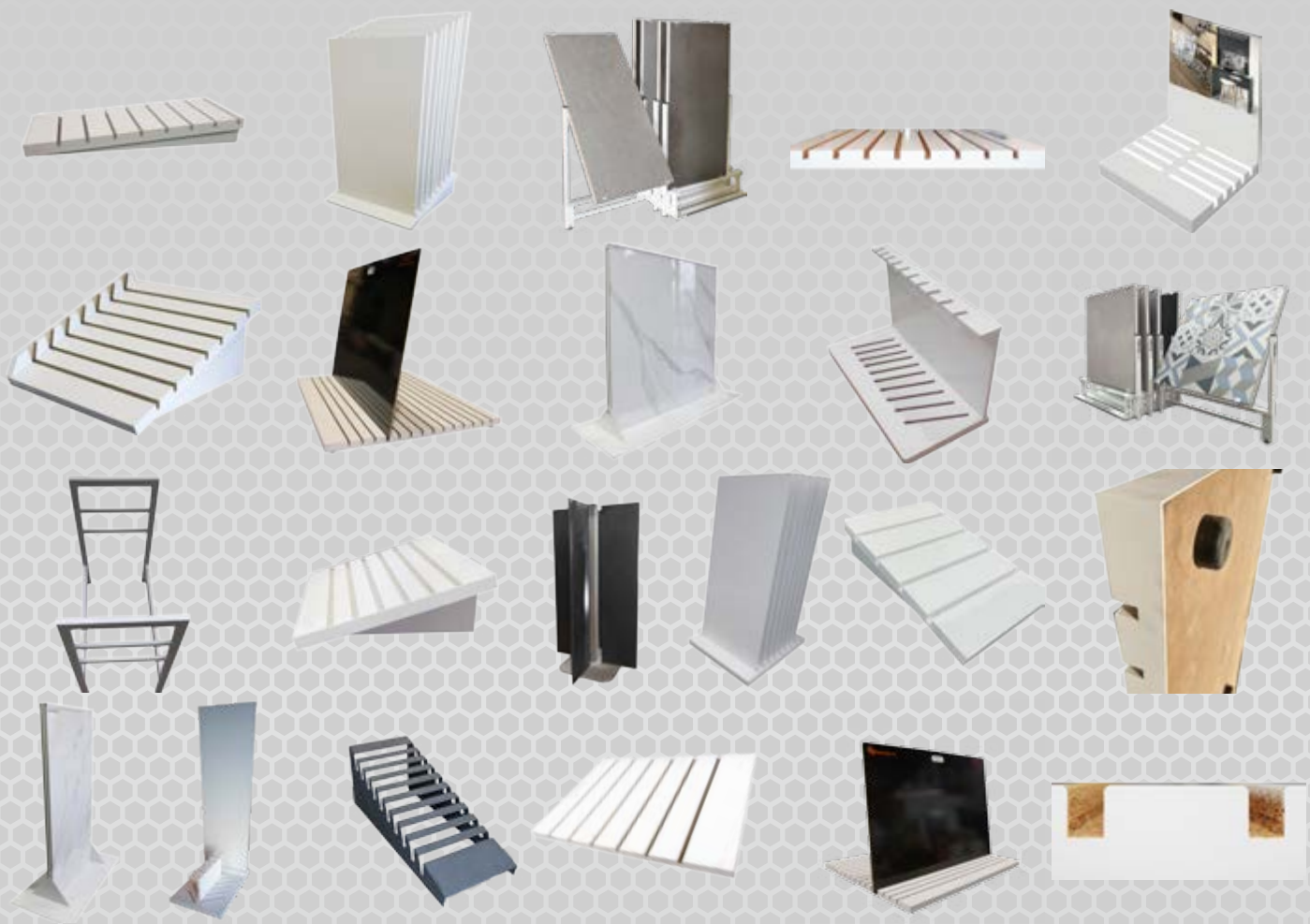

 **OSPANELI**

Tel: 964 60 53 30 / 667 741 357 / 691 655 089

gerencia@ondaservicios.es

www.ospaneli.es



SHOWROOMS

SHOWROOMS

MESA TECNICA POLIVALENTE

Fabricación Propia

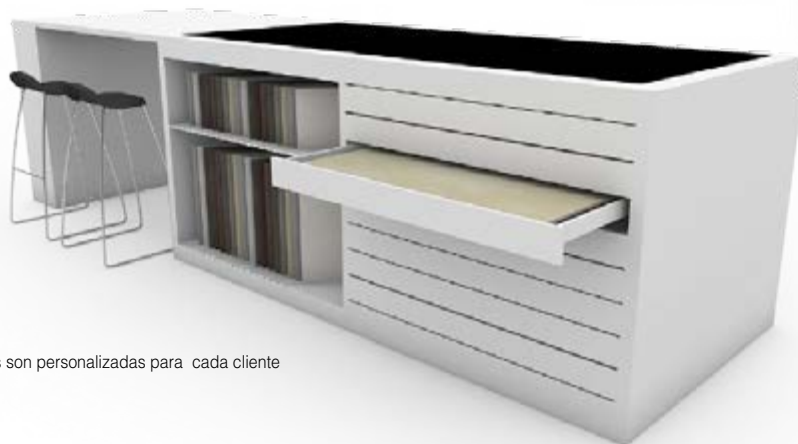
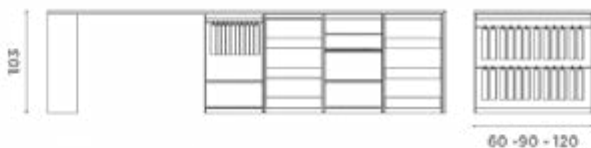

Las medidas de los muebles son personalizadas para cada cliente

No hay dos muebles iguales

Numero de bandejas

Anchura de cajones

Profundidad de mesa

Altura de mueble



SHOWROOMS

MUEBLE MULTIBANDEJA

Fabricación Propia



Las medidas de los muebles son personalizadas para cada cliente

No hay dos muebles iguales

Numero de bandejas

Anchura de cajones

Profundidad de mesa

Altura de mueble



SHOWROOMS

TECHNIC WALL TILES

Fabricación Propia

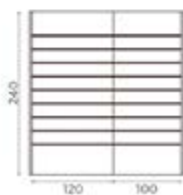

- A** BANDEJERO 6 | 30x30 HASTA 30x80
- B** SOPORTE 10 | 10R/20 - 10R/25 - 10R/35
- C** SOPORTE 5 | 5R/20 - 5R/25 - 5R/35
- D** PEINE 10 | BASE 60 - 10R
- E** ESTANTE 15 | DIAGONAL 60-15R
- F** ESTANTE 21 | RECTO 60-21R
- G** CENEFERO 9 | 60 - 9R
- H** BIBLIOTECA 16 | 30x30
- J** ATRIL 1 | 45x65 - 45x75 - 65x65
- K** BOOK 16 | 45x45 y 60x60
- L** TORRE 8 | 30x30 HASTA 80x80

Las medidas de los muebles son personalizadas para cada cliente.

SHOWROOMS

TECHNIC WALL MOSAIC

Fabricación Propia

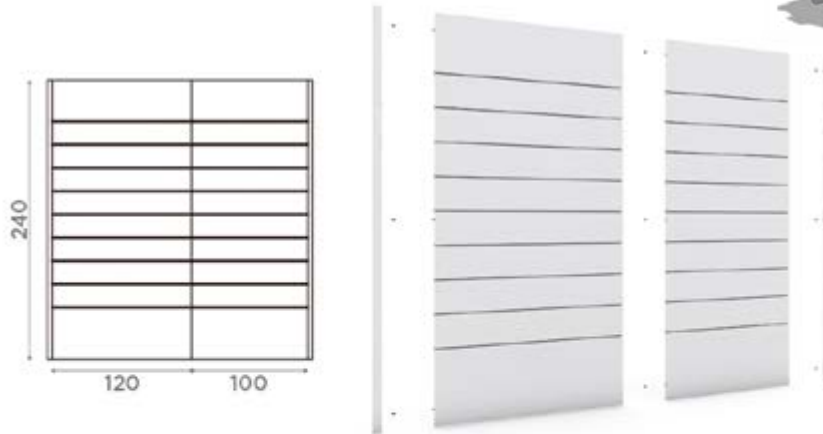

Las medidas de los muebles son personalizadas para cada cliente.



① TW/M01 ② TW/M02 ③ TW/M03 ④ TW/M04

SHOWROOMS

AMBIENTES INTERCAMBIABLES

Fabricación Propia



Las medidas son personalizadas para cada cliente.

SHOWROOMS

MUEBLES MODULARES

Fabricación Propia



RECTO



PERCHERO



A MEDIDA



CAJONES A3



CAJONES B3



CAJONES C3



CAJONERA 8



DIAGONAL

Las medidas son personalizadas para cada cliente.

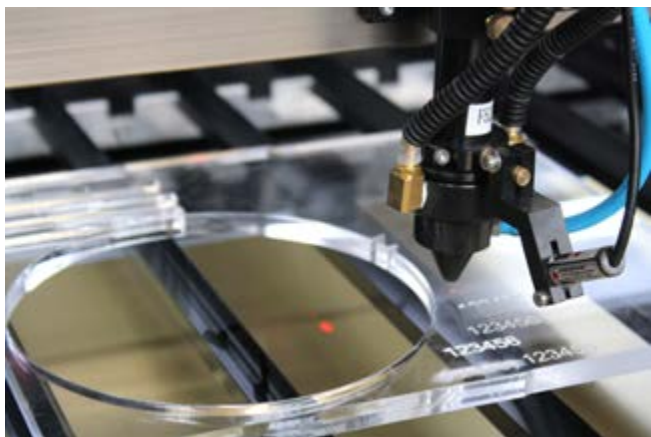

Máquina laser para grabado y corte



Plotter para impresión de vinilos de gran formato



Plancha para vinilo textil a 200°



Máquina para sublimación de tazas

 **OSPANELI**

Tel: 964 60 53 30 / 667 741 357 / 691 655 089

gerencia@ondaservicios.es

www.ospaneli.es



MAQUINARIA

ENFARDADORA PALETS



Fabricación Propia



ECOS PLUS MOTOR / ECO PLUS MOTOR 2000 mm

Velocidad de carro de bobina (variable por inverter)

Velocidad de giro en plataforma (variable por inverter) 6 / 14 r.p.m.

Carga máxima en plataforma 2.000 kg.

Dimensiones máximas de palet 1.500 x 1.500 mm.

Altura máxima de paletización 2.250 mm.

Regulación de vueltas de arriba a abajo A voluntad

Diámetro de la plataforma 1.650 mm.

Alimentación eléctrica 220 V Monofásica

Potencia instalada 0,736 Kw.

Tres ciclos de enfardado: manual, automático y con mantel superior.

Maniobra automática mediante autómatas PLC.

Arranque suave, parada exacta y puesta a cero de la plataforma.

Fotocélula para la detección de la altura de la carga.



DETALLE 1: MOTOR



DETALLE 2 : PLATAFORMA PARA PALETS DE 2000X1000 mm

PLUS 300 F

Máquina con todas las normas CE e ISO 9002

Carga máxima en plataforma 2.500 kg.

Dimensiones máximas de palet 1.500 x 1.500 mm.

Altura máxima de paletización 2.250 mm.

Diámetro de la plataforma 1.500 mm.

Alimentación eléctrica 220/380 V III.

Potencia instalada 1,28 Kw.

Función automática o manual completamente independientes con el sector de mando.

Maniobra automática mediante autómatas.

Fotocélula que limita la altura del palet automáticamente.

Apta para trabajar con film de preestiraje 300% mínimo.

Estiramiento del film motorizado. Mediante variador de frecuencia podemos dar estiro con lo que hay un ahorro considerable de film respecto los sistemas convencionales.

Indicador digital del porcentual de preestiraje instantáneo en cada momento.

Alarma acústica y visual que detecta la rotura del film o finalización de la bobina.

CONTENEDORES

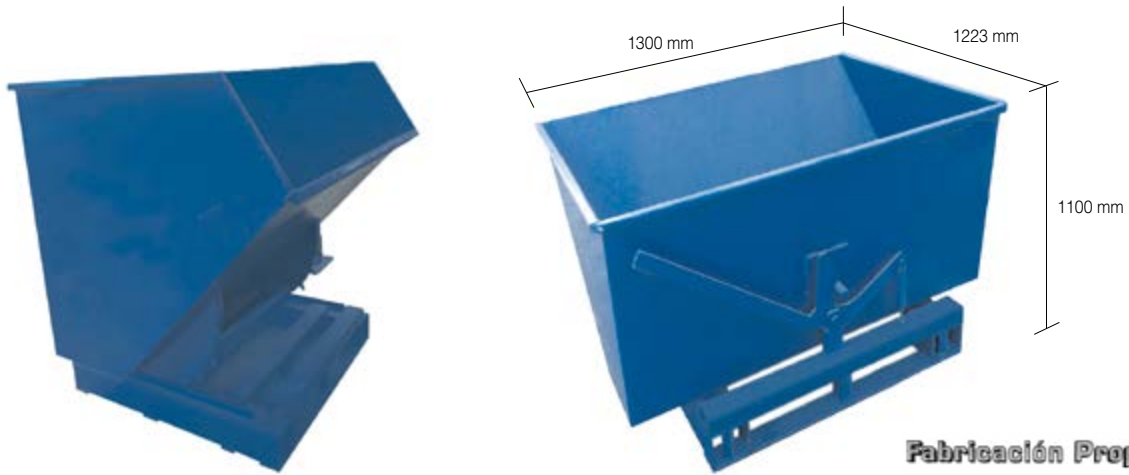

ANCHO (cm)	ALTO (cm)	PESO (Kg)	CAPACIDAD (cm ³)
125,0	109,7	220	1000

Fabricación Propia



MESA DE TRABAJO

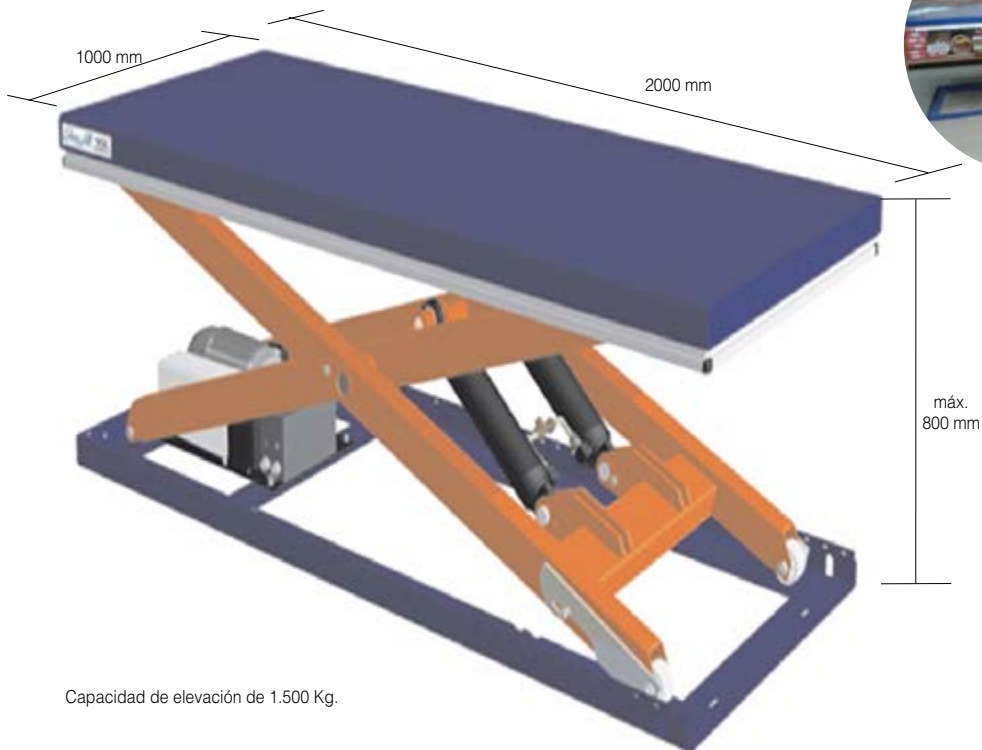

Capacidad de elevación de 1.500 Kg.

OS
AN
E

COMPRESORES



COMPRESOR DE TORNILLO 7,5 kW

MEDIDAS
125x59x160

POTENCIA DE MOTOR
64 db.

CAPACIDAD DE TANQUE DE AIRE
200 L

SUMINISTRO DE AIRE HASTA
740L/min

FUENTE DE ALIMENTACION
380 V 50 Hz

BASCULA / RAMPA

Fabricación Propia

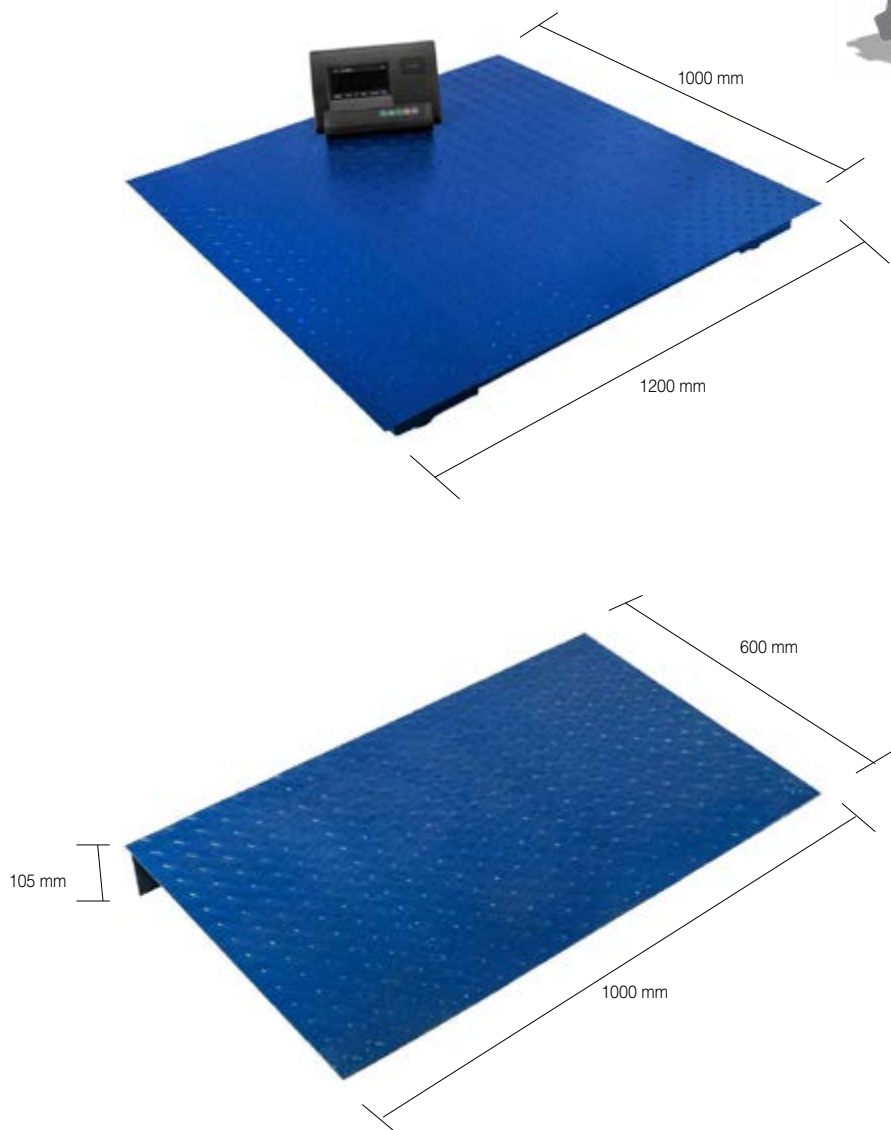

MEDIDAS	PESO MAX. SOPORTADO (Kg)	MATERIALES
120 x 100 x 10,5	4000	ACERO 4mm

Fabricado en acero de 4 mm de grosor, relieve damero antideslizante.
La rampa permite salvar el desnivel entre el suelo y la plataforma de la balanza

PINZA PICKING

IDEAL PARA PIEZAS HASTA 120 cm



BRAZO GIRATORIO + PINZA

PIEZAS DESDE 45X45

HASTA 60X120

ABATIBLE

90°

BRAZO GIRATORIO + PINZA

- Pinza neumática abatible 90 grados
- Apertura máxima de la pinza 130 cm
- Poste central anclado al suelo mediante zapata de hormigón
- Elevación mediante pistón neumático
- Longitud máxima del brazo 4 metros
- Actuadores y sistemas de mando neumáticos
- Pulsadores de mando integrados en la pinza
- Sistema de seguridad de apertura y cierre de la pinza

Fabricación Propia



Pinza fabricada con medidas personalizadas
Elaboración propia

ALARGADOR DE PALAS TORITO



Fabricación Propia



FACIL MONTAJE

2METROS

SUJECION OPTIMA CON EL
PASADOR FIJO

Largo 2000mm
Chapa doblada de 6mm
Válido para horquilla de 1000mm y 100mm de ancho
Fabricadas en acero, alta capacidad de carga
Marcado CE

W
S
A
N
E
L

IMAGEN CORPORATIVA

FOLDERS / CARPETAS

Fabricación Propia



RETRACTILADOS



IMAGEN CORPORATIVA

ROTULACION VEHICULOS

Fabricación Propia

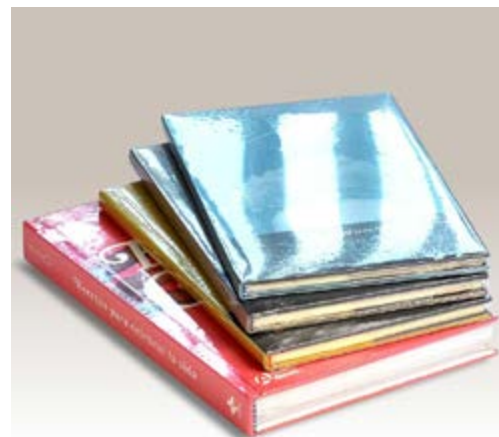

ROPA LABORAL



IMAGEN CORPORATIVA

CATALOGOS



FLYERS



Fabricación Propia



TARJETAS



MERCHANDISING



IMAGEN CORPORATIVA

SUBLIMACION



BORDADOS



SERIGRAFIA



Fabricación Propia

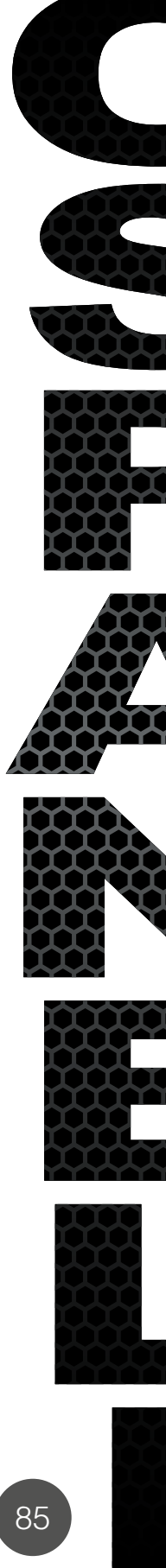

W
S
A
N
E
E
E

IMAGEN CORPORATIVA

Fabricación Propia



VINILO IMPRESION



VINILO TEXTIL



IMAGEN CORPORATIVA

CORTE LASER



Fabricación Propia



PLANTILLAS

PLANTILLAS PERSONALIZADAS PARA PINTAR			
MATERIALES	Aluminio	3 mm	GROSOR
	PVC	5 mm	
	DM	8 mm	

Para otro material o diferente grosor, consultar



DISEÑO PERSONALIZADO

PLANTILLAS REUTILIZABLES



FORNERS
VASANTEC
REINSU
AZULEJOS MALLOL

IMAGEN CORPORATIVA

ROTULOS / MONOPOSTES

Fabricación Propia



IMAGEN CORPORATIVA



Fabricado en lona

Fabricación Propia



Fabricado composite, impresión directa



Fabricado en lona, rotulo luminoso

DISPLAYS



Fabricado en lona



Fabricado en PVC

IMAGEN CORPORATIVA

EXPOSICIONES



IMAGEN CORPORATIVA

STANDS

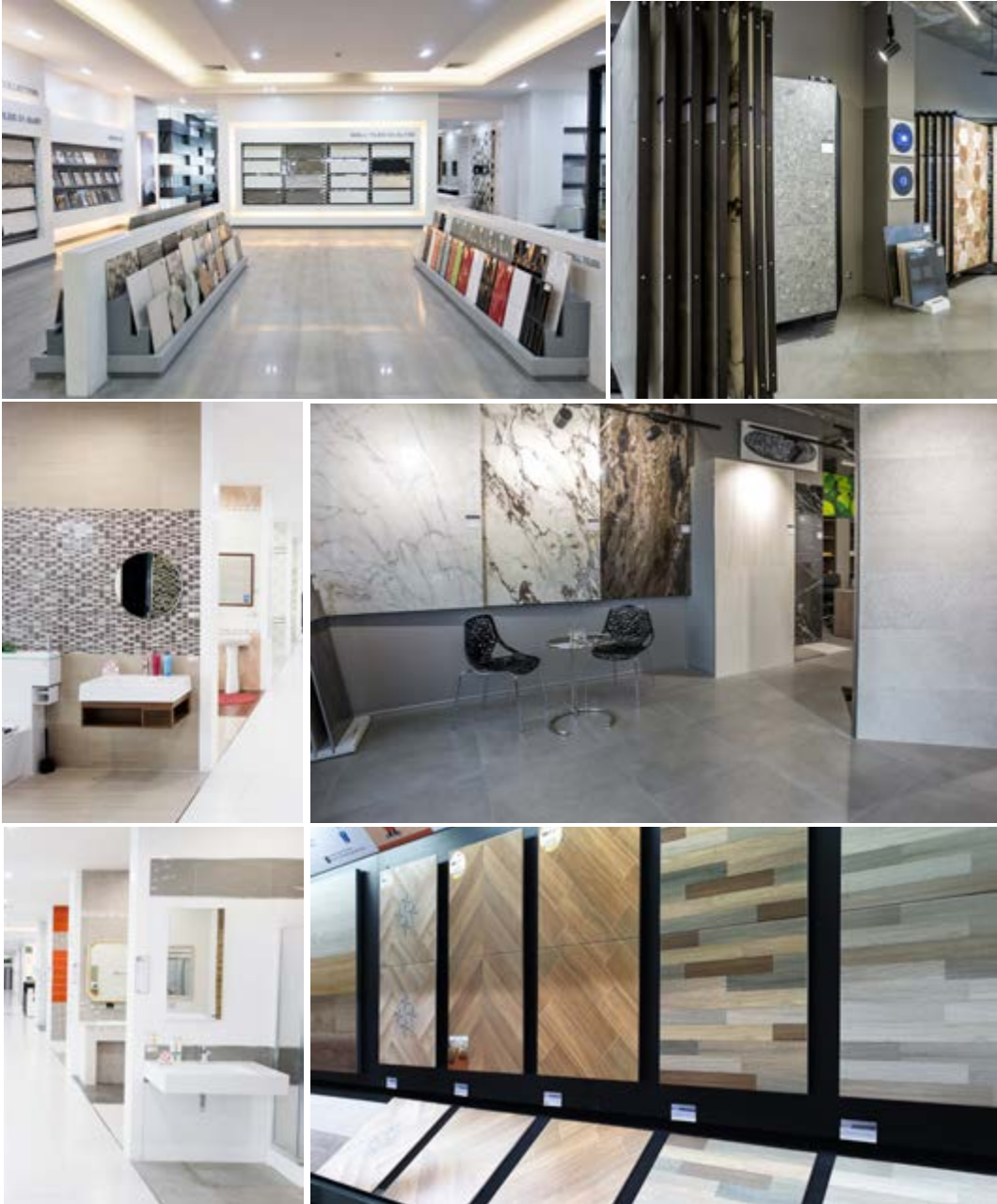

Diseñamos el showroom desde cero
Diseño personalizado
Espacios diferentes
Presentaciones en 3D

**S
P
A
N
E
L
E**

NOTAS

.....

.....

.....

.....

.....

.....

.....

.....

.....

.....

.....

.....

.....

.....

.....

.....

.....

.....

.....

.....

.....

.....

.....

.....



ONDA SERVICIOS PANELES DE IMAGEN S.L.

667 741 357 / 691 655 089

gerencia@ondaservicios.es

www.ospaneli.es





ONDA SERVICIOS PANELES DE IMAGEN S.L.

Pol. El Colador, C/ Islas Canarias nº18

Tel: 964 60 53 30 / 667 741 357 / 691 655 089

gerencia@ondaservicios.es

www.ospaneli.es